



WE **THANK YOU** FOR YOUR PURCHASE OF OUR MODEL
MG22 MEAT GRINDER.

*All of us . . .
at Univex!*



TABLE OF CONTENTS

DESCRIPTION	PAGE
Table of Contents	1
Operator Safety	1
Installation	2
Assembly and Operating Instructions	2-3
Cleaning	3
Parts List	4-5
Assembly	6
Wiring Diagram 115/208-230 V, 60HZ, 1 PH / 220-240V, 50HZ, 1 PH	7
Wiring Diagram, Canada, CE, 115/208-240 V, 60HZ, 1PH / 230V.50HZ, 1PH	8
Warranty Information	Back Cover

MG22 MEAT GRINDER INSTRUCTION MANUAL

Inspection:

All Univex MG22's are inspected prior to packaging to assure both the machine quality, correct inclusion of options, and proper voltage. However, upon unpacking, all items should be carefully verified that they are correct. Any damage, imperfection, or shortages should be reported immediately to your dealer or directly to Univex Customer Service, and/or shipment carrier.

Operator Safety:

- Read and understand all instructions and safety warnings prior to operating unit
- Never put fingers or any utensils (other than the stomper (Item 10) in the throat or entry of the grinder, or in the knife and plate area of the grinder. This is a powerful unit designed to grind meat, use extreme caution and avoid exposing body parts to grinding and cutting areas of the unit
- Switch the power off and disconnect the electric power supply prior to mounting and dismantling the grinder, cleaning, or servicing
- Knife is sharp and can cut finger. Use caution when handling
- Always have chopper securely mounted, worm assembly fully coupled onto drive coupling, and the knife, plate, and ring snugged on before switching the power on
- Always remove the grinder from the power drive before cleaning, never rinse with hose while mounted to power source, inviting electrical shock

Installation:

- This is a table-top unit. Unit may be secured to table top via the shipping bolt threaded holes on the power drive housing bottom.
- Insure the unit is located such that it is placed on a level and stable surface, and sufficient clearance is provided all around the unit for safety and ease of operation. Proper location includes space for the feed pan and clip-on storage container.
- Feed pan support bracket (Item 45) must be assembled onto the housing cover (Item 43) using the screws (Item 46) provided.

ASSEMBLY AND OPERATING INSTRUCTIONS:**Introduction:**

The Univex MG22 Meat Grinder consists of a 1 H.P. electric motor power base which drives a bell-shaped meat grinder designed to utilize industry standard #22 knives and full range of #22 grinding plates. Included as standard equipment is a carbon steel knife (Item 3), 3/16 grinding plate (Item 2), aluminum meat stomper (Item 10), 16 x 24 aluminum feed pan (Item 9) for holding meat to be processed, and 18.5 x 13.5 storage container with lid for collecting meat as it is processed.

The Univex MG22 has safety and ease of operation built into it. The permanent safety guard positioned over the bell-shaped feed hopper prevents accidental entry of operator's fingers and hands into the grinding zone. The readily removable feed pan and storage container provide for ease of processing and cleaning.

Noise emissions below 70 db (A).

Assembly:**WARNING: Disconnect power supply prior to assembly.**

1. Mount the housing-guard assembly (Item 8) to the housing weldment (Item 26) by firmly tightening knobs (Item 12) onto mounting studs (Item 14).
2. Slide the worm assembly (Items 6,5,4) into the housing-guard assembly (Item 8) and mating into the drive coupling (Item 15).
3. Slide the knife (Item 3), sharp edges toward the plate, onto the square of the worm assembly (Item 4). Slide the plate (Item 2) onto the worm assembly (Item 4). Screw the ring (Item 1) onto the housing-guard assembly (Item 8) until it is just snug. Too much pressure can damage the unit.

WARNING: The knife is sharp and can cut fingers.

4. Guide the feed pan (Item 9) over the guard portion of the housing-guard assembly (Item 8) onto the pan stud (Item 7) and the pan support (Item 44).
5. Locate the storage container under the clip (Item 24) and resting on the front legs (Item 23).
6. Connect power supply and actuate power switch (Item 25).

WARNING: Never put fingers or utensils in the throat of the grinder or the knife and plate interface.

Process:

1. Cut meat to be processed to fit under or through the safety guard. Recommended size is 1 1/2" thick x 3" wide x 12" long. Set meat in pan (Item 9).
2. With grinder running, slide product under the guard of the housing-guard assembly (Item 8) or through the openings in the guard top. Use the meat stomper (Item 10) if desired, to guide product into grinding zone. The stomper is recommended for regrind.
3. Collect ground product in storage container.

Cleaning:

1. Turn unit off and disconnect from power supply.
2. Disassemble unit in reverse of assembly instructions — Remove storage container, feed pan, and then ring, plate, knife, worm assembly, and housing-guard assembly.

WARNING: The knife is sharp and can cut fingers.

3. Clean components including the drive coupling (Item 15) by following the procedure: wash, rinse, sanitize, and air dry. Use the bristle brush provided to clean areas difficult to access. Apply a small amount of food grade lubricant to bronze bushing, located inside the housing-guard assembly (Item 8), before use.

ASSEMBLY

MG22

<u>ILLUS.</u>	<u>PART NO.</u>	<u>DESCRIPTION</u>	<u>QTY.</u>
1	1000719	RING, #22	1
2	1000727	PLATE, 3/16"	1
	1000726	PLATE 1/8' (OPTIONAL)	
	1000728	PLATE 1/4' (OPTIONAL)	
	1000729	PLATE 3/8' (OPTIONAL)	
	1000730	PLATE 1/2' (OPTIONAL)	
3	1000725	KNIFE, #22	1
4	1000715	SHAFT, FRONT	1
5	1000711	WORM, #22	1
6	1000717	COUPLING, WORM	1
7	1000731 *	STUD, PAN	1
8	1000709 *	HOUSING-GUARD ASSY	1
9	8700214	PAN	1
10	1000735	STOMPER	1
11	1000724	LOCK PIN, PLATE	1
12	8700222	KNOB	2
13	4400275	STUD - SWITCH ACTUATOR	1
14	1000718	STUD, MOUNTING	2
15	1000713	COUPLING, DRIVE	1
16	1200412	SET SCREW 1/4 - 20 X 1/4 CUP PT.	2
17	1200359	SCREW HEX. HD. SS CAP 3/8-16 X 1 1/2" LG.	6
18	1000722	WASHER, MOTOR	1
19	4400500	KEY 1/4 SQ. X 1 1/2	1
20	4400015	KEP NUT 3/8-16	8
21	8700219	GEAR MOTOR	1
22	8700220	SLEEVE, FRONT LEG	2
23	8700211	LEG, FRONT	2
24	8700216	CLIP, BUSS BOX	1
25	8700218	SWITCH, START/ STOP	1
26	8700210	HOUSING, WELDMENT	1
27	1200432	SCREW HEX. HD. CAP 4-40 X 3/4 LG.	2
28	7100103	SWITCH, SAFETY	1
29	7100023	INSULATOR, SAFETY SWITCH	1
30	1024414	BRACKET, SAFETY SWITCH	1
31	1200433	ELASTIC STOP NUT 4-40	2
32	1200076	WASHER 10	6
33	4400065	LOCK WASHER 10	6
34	1200060	HEX NUT 10-32	7
35	7510252	ELASTIC STOP NUT - M10 X 1.5	2
36	7100011	CONTACTOR 115V, 60HZ.	1
	7100015	CONTACTOR 100V, 50-60 HZ	
	7100012	CONTACTOR 230V, 60HZ	
	7100040	STARTER, 115V, 60HZ (CANADA ONLY)	
	7100116	STARTER, 230V, 60HZ, (CANADA ONLY)	
	7100108	STARTER, 230V, 50HZ, 1PH (EUROPE ONLY)	
	7100016	CONTACTOR, 220-240V, 50HZ,	
37	7100010	RAIL, DIN	1
38	4400155	SCREW HEX. HD. CAP 1/4-20 X 1/2 LG.	2
39	4400005	LOCK WASHER 1/4	2
40	1814118 **	LEG, REAR	2
41	8512855	FEET, REAR	2
42	7100107	STRAIN RELIEF	1
43	8700212	COVER, HOUSING	1
44	8700215	SUPPORT, PAN	1
45	8700217	SLEEVE, PAN SUPPORT	2
46	4400246	SCREW, FLAT HD SLT SS 10-32 X 3/4	2
47	1200012	SCREW PPHD. 10-32 X 1/2 LG.	6
48	8700014	RUBBER STRIP	
49	8700105	STORAGE CONTAINER (NOT SHOWN)	1
50	8800200	POWER CORD (NOT SHOWN)	1
51	8800208	CORD, MOTOR (NOT SHOWN)	1
52	4400326	LABEL, UNIVEX (NOT SHOWN)	1
53	4400351	LABEL, (NOT SHOWN)	1
54		RESERVED	
55	1000732	BRUSH, CLEANING (NOT SHOWN)	1
56	4400401	CONNECTOR, 3/8 (NOT SHOWN)	1
57	8800229	WIRING PKG, (NOT SHOWN)	1

* ILLUS. NO. 7 IS INCLUDED WITH ILLUS. NO 8

** ILLUS. 40 INCLUDES STUD M10-1.5 X 22MM

ASSEMBLY

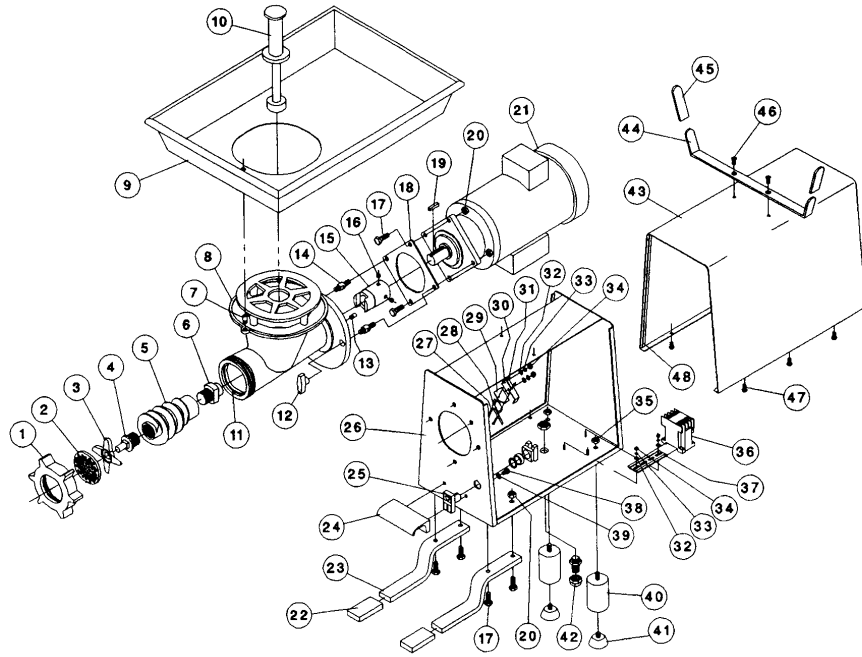

WIRING DIAGRAM
115/208-230V, 60HZ, 1PH
220-240 V, 50HZ, 1PH

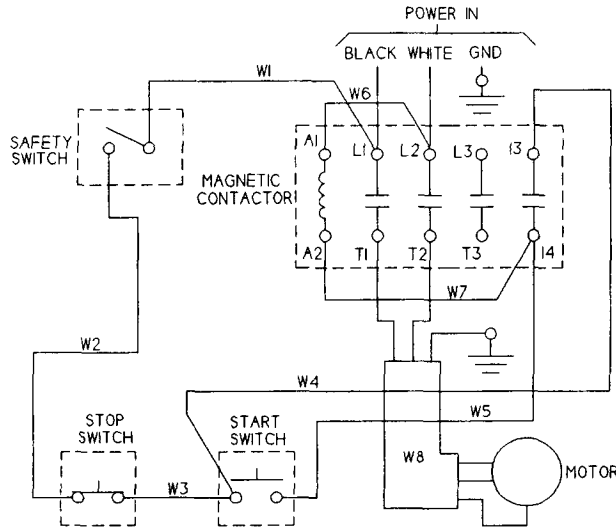

WIRE TABLE							
PART NUMBER	WIRE NO.	GA	SEE NOTE	LENGTH IN INCHES	END A SEE NOTE	END B SEE NOTE	COLOR
8800229	W1	16	3	33	1	2	WHITE
	W2	16	3	13	1	2	WHITE
	W3	16	3	2 1/2	1	1	RED
	W4	16	3	24	1	1	BLACK
	W5	16	3	26	1	1	RED
	W6	16	3	2 1/2	1	1	RED
	W7	16	3	2 1/2	1	1	RED
8800208	W8	MOTOR CORD					

- NOTES: 1 DOUBLE CRIMP FERRULES. KLAUKE 72/10VZ OR AMP 925553-2.
 2. MOLEX - ETC BB - 5623.
 3. MATERIAL: 16GA 1015 TEW CSA AND UL APPROVED.

IMPORTANT: Before making electrical connections, check the specifications on the data plate (located on the rear panel) to assure they agree with those of your electrical service.

WARNING: Whenever maintenance is being performed, or whenever the top cover has been removed, DISCONNECT electrical cord and place a tag on it indicating the slicer is being worked on.

**WIRING DIAGRAM
CANADA & CE 115/208-240
V, 60HZ, 1PH 230V, 50HZ,
1PH**

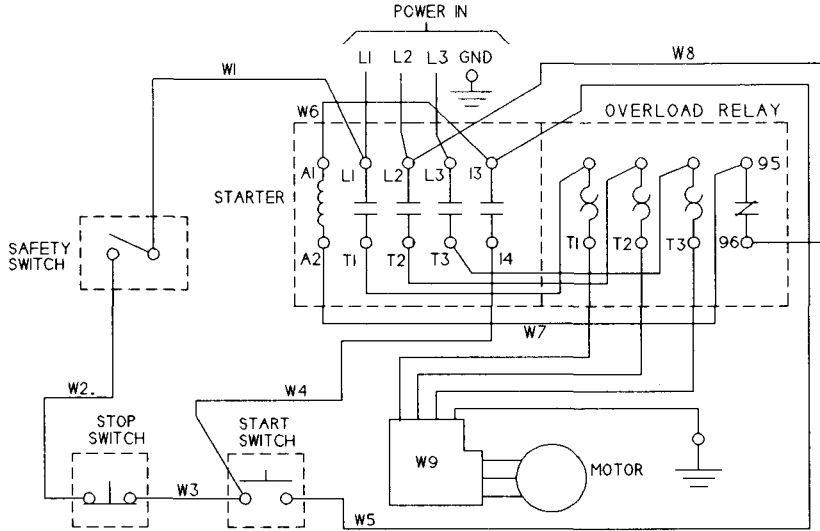

WIRE TABLE								
PART NUMBER	WIRE NO.	GA	SEE NOTE	LENGTH IN INCHES	END A SEE NOTE	END B SEE NOTE	COLOR	
8800229	W1	16	3	33	1	2	WHITE	
	W2	16	3	13	1	2	WHITE	
	W3	16	3	2 1/2	1	1	RED	
	W4	16	3	24	1	1	BLACK	
	W5	16	3	26	1	1	RED	
PART OF STARTER	W6	16	3	2 1/2	1	1	RED	
	W7	16	3	5 1/2	1	1	RED	
	W8	16	3	8 1/2	1	1	RED	
8800208	W9	MOTOR CORD						

- NOTES: 1 DOUBLE CRIMP FERRULES. KLAUKE 72 / 10VZ OR AMP 925553-2.
 2. MOLEX-ETC BB-5623.
 3. MATERIAL: 16GA 1015 TEW CSA AND UL APPROVED.

IMPORTANT: Before making electrical connections, check the specifications on the data plate (located on the rear panel) to assure they agree with those of your electrical service.

WARNING: Whenever maintenance is being performed, or whenever the top cover has been removed, DISCONNECT electrical cord and place a tag on it indicating the slicer is being worked on.