

# INSTRUCTION MANUAL

*. . . with Catalog of Replacement Parts*

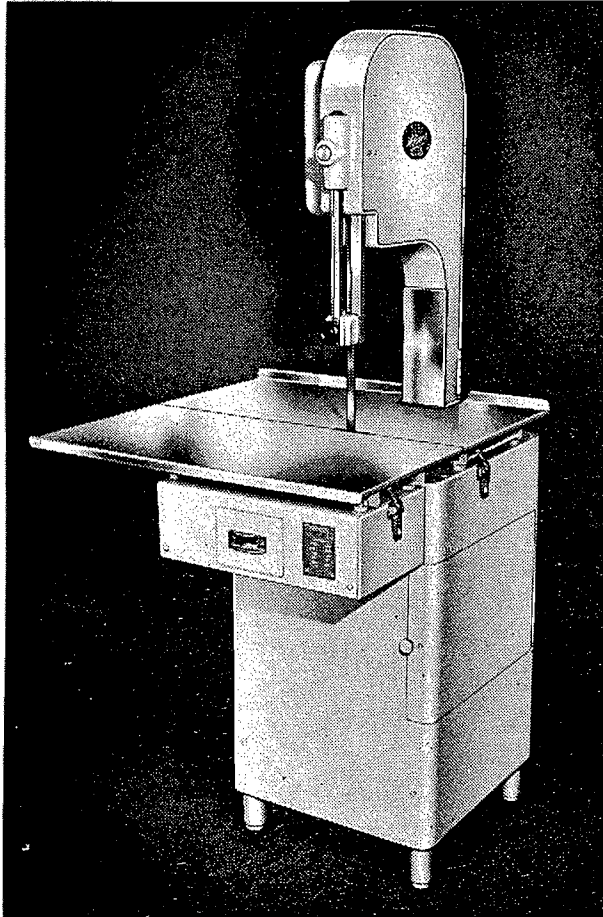

## HOBART

MODELS 5012-F and 5012-FD  
MEAT SAWS

Spec. #9104 STANDARD

Spec. #9347 DELUXE

## THE HOBART MANUFACTURING COMPANY



*The World's Oldest and Largest Manufacturer of Computing Scales  
and Food Store, Kitchen, Bakery and Dishwashing Machines*

**TROY, OHIO, U. S. A.**

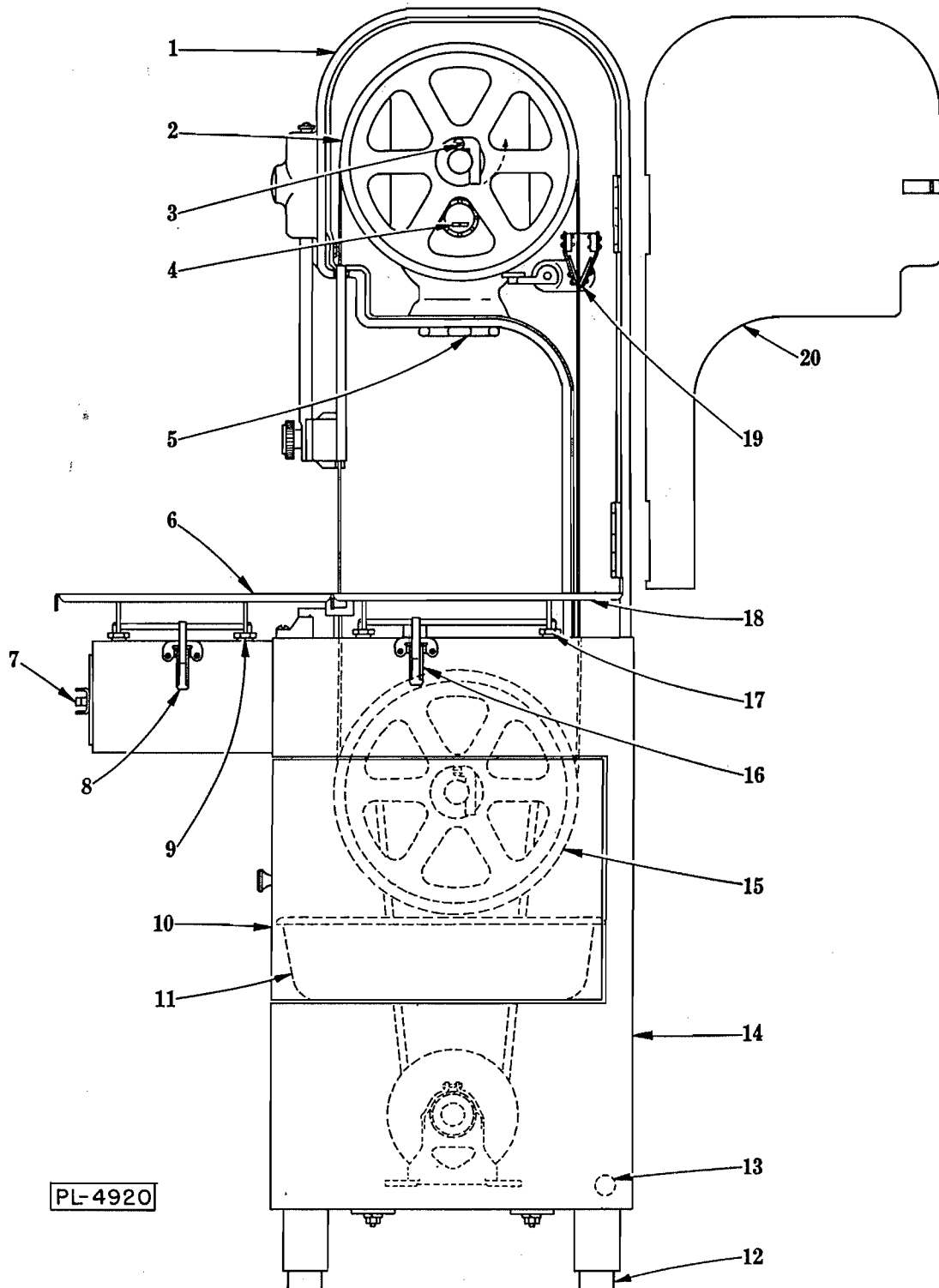

FIG. 1

# Installation, Operation and Care of

## MODELS 5012-F and 5012-FD MEAT SAWS

### I — UNPACKING

Remove the shipping box that covers the saw. Next, unpack the table, table extension and the four feet which were disassembled for shipping purposes. (Instructions for reassembly are given in "Setting-up" section). Unpack the scrap pan inside the cabinet. Remove the four retaining bolts from the underside of the skid.

### II — SETTING UP

(1) Place the machine in the location where it is to be used. Assemble the feet (12, Fig. 1). Place a spirit level on top of the base unit and adjust the feet in the legs so that the base unit is level from side to side and front to back.

(2) Lower the upper blade pulley (2, Fig. 1) by giving the tension adjustment hand wheel (5, Fig. 1) a few turns to the left. Open the head door (20, Fig. 1). Lift out the lower wiper unit (Fig. 3) and place the saw blade over the upper (2, Fig. 1) and lower (15, Fig. 1) blade pulleys. The teeth must point to the right and downward when viewed from the front as shown in Fig. 3. If they do not point downward, remove the blade, twist inside out and replace it on the saw. Make sure the blade is centered in the upper blade wiper (19, Fig. 1) and properly placed in the upper guide unit (Fig. 2).

Turn the tension adjustment hand wheel (5, Fig. 1) to the right until the tension indicator (4, Fig. 1) reads "2". Give the upper pulley a few turns by hand so that the blade centers itself on the pulleys, then turn the tension adjustment hand wheel slowly to the right until the indicator registers between "3" and "4". This is the best operating tension for the blade.

**NOTE:** See paragraph IX for adjustment of blade back-up blocks.

(3) Put in the lower wiper unit (Fig. 3). Before sliding it into place, swing up the bakelite guard (1, Fig. 3) and see that the saw blade is between the two wipers (3, Fig. 3) and in the guide slot of steel block (5, Fig. 3). After sliding the unit into place, close down the bakelite guard (1, Fig. 3).

(4) Put on the table (1, Fig. 4). Locate table in position by the locating block (3, Fig. 4), being sure the support angles on the underside of the table are inside the locating pins of the four table rests (17, Fig. 1) on the base (14, Fig. 1). Then lock in place by closing the table clamps (16, Fig. 1) at each end.

(5) Assemble the table extension (4, Fig. 4) with the support angles on the underside of the extension inside the four table rests (9, Fig. 1). The locating block (3, Fig. 4) is used for positioning the extension. Lock in place by closing the table clamps (8, Fig. 1) at each end.

### III — WIRING

Before connecting to the power line, check the data on the name plate (5, Fig. 4) to make sure that the motor is correct for your electric service. Make your installation connection from the power line directly to the switch (7, Fig. 1). In order to avoid having conduit at the front of the machine, it is recommended that flexible (or rigid) conduit be connected through the electric inlet hole (13, Fig. 1) in the base (14, Fig. 1). The motor and switch are connected at the factory.

Be sure to use wire large enough to meet your local code requirements. For proper performance use wire sizes of NOT LESS than #12 gage for 115 V., or #14 gage for 230 V. on single phase models. Use #14 gage for 208, 220, and 440 V. on three phase models. For long runs, between power inlet and saw, use a larger size.

### IV — SAFETY FEATURES

The Hobart Saw is provided with safety devices to give maximum protection to the operator.

**KEEP THE GUARDS IN PLACE AT ALL TIMES.**

(1) **UPPER GUIDE ASSEMBLY** (Fig. 2). Keep as low as the size of the work permits.

(2) **UPPER BLADE GUARD**. Keep in vertical position.

(3) **DOORS**. Keep doors (10 & 20, Fig. 1) closed when the machine is running.

### V — LUBRICATION

Very little lubrication is required, because all the high-speed shafts have roller or ball bearings which are grease-packed and will operate a long time without attention.

(1) Once a year, have a Hobart service man look over the motor and main bearing carriers.

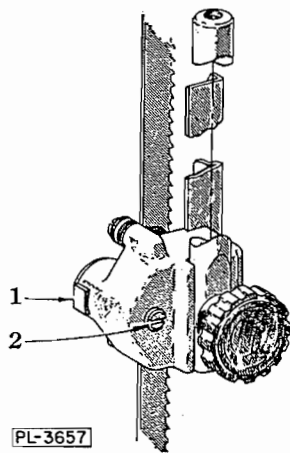

FIG. 2

## VI — OPERATION

Place the item to be cut on the table extension and turn on the motor switch. Stand in front of the machine and feed the material to be cut with a steady and uniform speed. Move your left hand around the left side (back side) of the saw blade when reaching for an item; NEVER IN FRONT OF THE TEETH.

The saw cuts through bone and meat alike, and no preliminary preparation with the butcher knife is necessary as with a hand saw.

## VII — CLEANING

It is very important that any appliance used in preparation of food be kept in a clean and sanitary condition. This machine has been designed to make cleaning a quick and easy job.

Daily cleaning is recommended.

### SUGGESTED CLEANING PROCEDURE

(1) Release table clamps (8, Fig. 1) and lift off table extension (6, Fig. 1).

(2) Release table clamps (16, Fig. 1) and remove stainless steel table (18, Fig. 1).

(3) Loosen hand knob (that retains upper blade wiper), bump with hand to loosen stud and then remove hand knob. Open head door (20, Fig. 1) and lift out upper blade wiper (19, Fig. 1). Clean unit and lubricate with TASTELESS oil.

(4) Swing lower saw blade guard (1, Fig. 3) up and lift out lower wiper assembly. Clean unit thoroughly and LUBRICATE WITH TASTELESS OIL.

(5) Remove Scrap pan (11, Fig. 1).

(6) Release blade tension by turning tension adjusting hand wheel (5, Fig. 1) to the left. Open head door and swing the upper blade guard down to horizontal position. Remove saw blade.

(7) To remove the upper guide unit (Fig. 2), remove the hand knob (2, Fig. 4) (blade tension already released) then lift off unit. Clean, lubricate with TASTELESS oil and replace.

(8) Remove upper and lower pulleys by swinging the pulley retaining latches (3, Fig. 1) clear of the shafts. Slide pulleys off. Clean pulleys and oil bore before replacing.

All areas are now exposed for easy thorough cleaning.

NOTE: When replacing pulleys, make sure that pulley latches are properly seated in grooves of shaft. Also the blade and pulley wipers must be in proper operating positions.

## VIII — CHANGING SAW BLADES

(1) Release table clamps and lift off table extension.

(2) Release table clamps and remove table.

(3) Lower upper blade pulley by turning tension adjusting hand wheel to left.

(4) Open head door and swing upper blade guard to horizontal position. Swing up lower blade guard and remove blade.

(5) Put on the new blade, turn the hand wheel to the right until the indicator reads "2", turn the upper blade pulley (2, Fig. 1) by hand to center the blade, and then turn the hand wheel

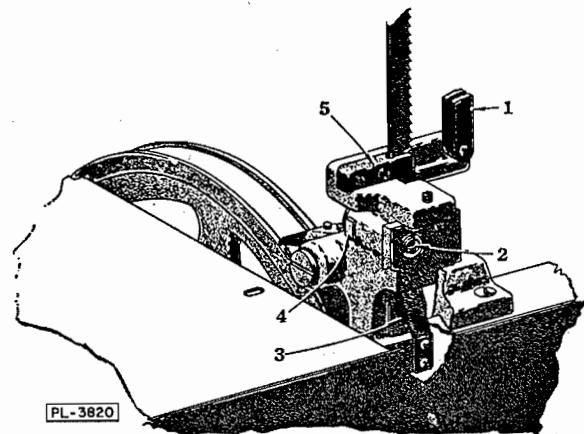

FIG. 3

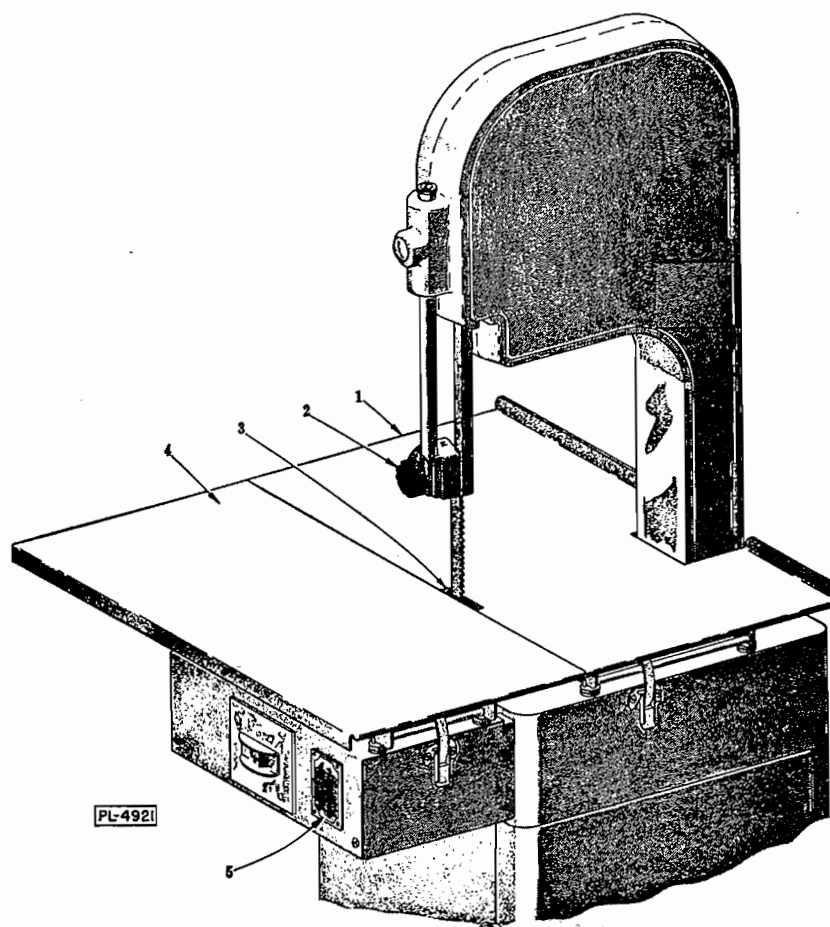

FIG. 4

until the indicator registers between "3" and "4". Make sure the upper blade wipers (19, Fig. 1) are on both sides of blade.

#### IX — ADJUSTMENT OF BLADE BACK-UP BLOCK

At the back edge of the saw blade in the upper guide (1, Fig. 2) and the front lower wiper unit (4, Fig. 3) are special tungsten carbide blade back-up blocks (eliminating the old fashioned ball bearing back-up). These special blocks take the cutting thrust. The clearance between these blocks and the blade, with the saw running with-

out load, should be approximately  $1/32''$ . Always check this dimension after changing blades. These back-up blocks should be adjusted to suit any variation in blade widths.

NOTE: Adjust the upper back-up block (1, Fig. 2) by turning screw (2, Fig. 2) and lower back-up block (4, Fig. 3) by turning the screw (2, Fig. 3).

#### X — BLADE REPLACEMENT

Two saw blades are furnished as regular equipment with every machine. Replacement blades are available thru all Hobart offices.

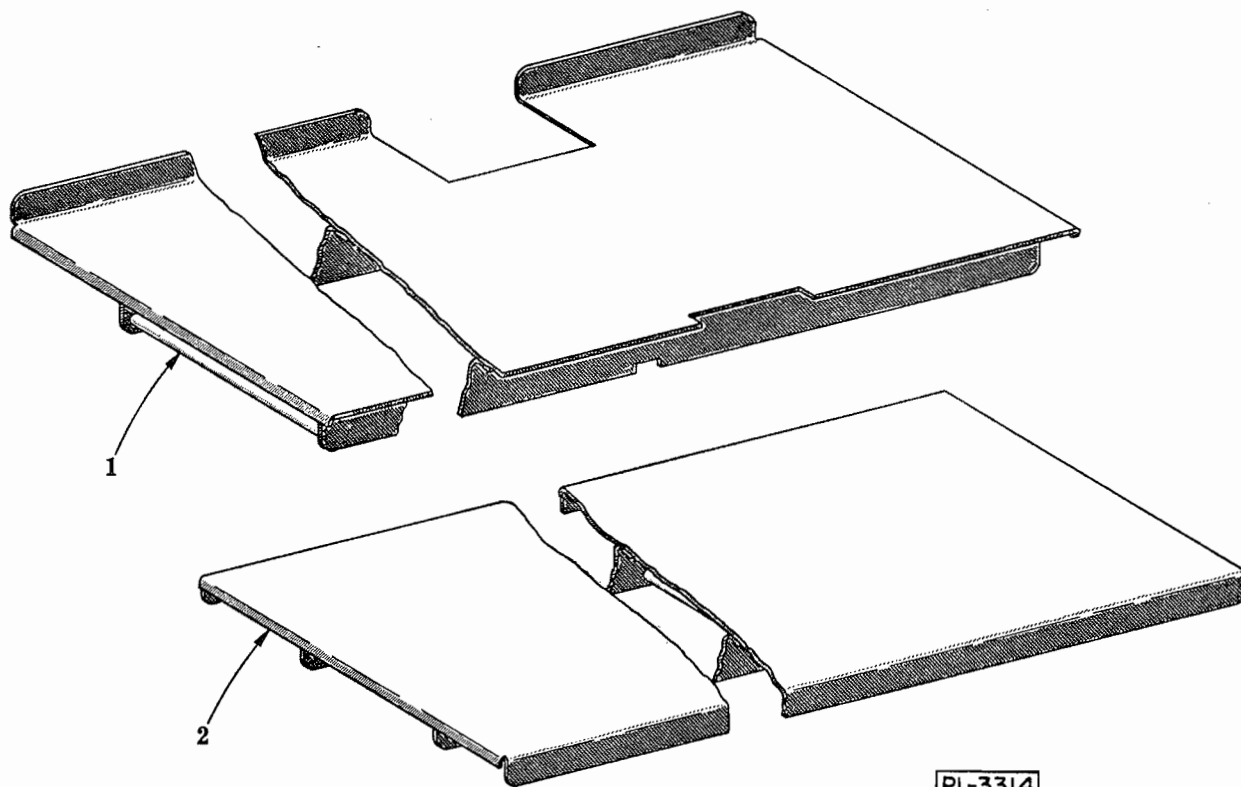

**TABLE AND TABLE EXTENSION UNIT**

ILLUS. NO.	PART NO.	NAME OF PART	AMT.
1	S-67162-2	Table Assy. -----	1
2	S-70182	Table Extension Assy. -----	1

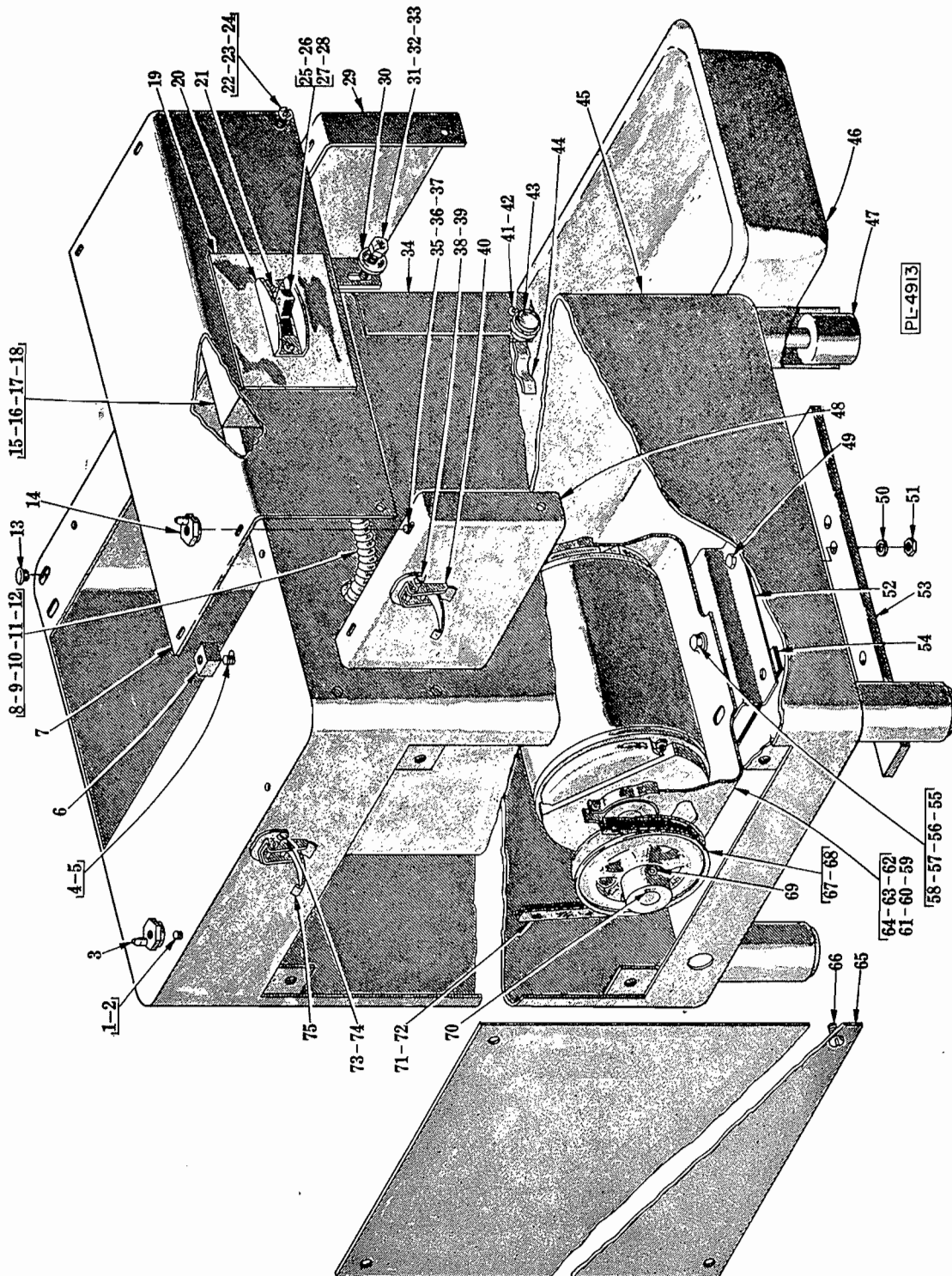

BASE AND MAIN FRAME UNIT

## BASE AND MAIN FRAME UNIT

ILLUS. PL-4913	PART NO.	NAME OF PART	AMT.
1	SC-36-14	Fin. Bolt - 1/4"-20 x 1/2" Hex Hd. -----	4
2	WL-3-38	Lock Washer - 1/4" x .109" x .062" -----	4
3	M-67153	Table Rest Assy. -----	4
4	SC-36-13	Fin. Bolt - 1/4"-20 x 3/4" Hex Hd. -----	1
5	WL-3-38	Lock Washer - 1/4" x .109" x .062" -----	1
6	M-67145	Locator - Table -----	1
7	S-70187	Base Cover Plate Assy. -----	1
8	-----	Open Number -----	
9	-----	Open Number -----	
10	FE-2-17	Connector - 90° (1/2" Male Thd. x 1/2" Flex. Cnd.) -----	2
11	P-24127-65	Conduit - 1/2" x 30" Flex. -----	1
12	BF-2-19	Bushing - 1/2" Anti-Short -----	2
13	PB-2-20	Plug Button (Plugs Gage Plate Support Holes) -----	4
14	M-67153	Table Rest Assy. -----	4
15	P-67300	Switch Box Assy. -----	1
16	SC-9-28	Mach. Screw - #10-24 x 3/8" Rd. Hd. -----	2
17	WL-3-20	Lock Washer - #10 x .055" x .040" -----	2
18	NS-9-24	Mach. Nut - #10-24 Hex -----	2
19	P-71380	Plate - Switch Cover -----	1
20	M-14506-3	Shield - Switch -----	1
21	SC-9-44	Mach. Screw - #6-32 x 1/2" Rd. Hd. -----	2
22	SC-10-13	Mach. Screw - #10-24 x 3/8" Truss Hd. -----	2
23	WL-4-40	Lock Washer - #10 x .062" x .047" -----	2
24	NS-9-22	Mach. Nut - #10-24 Hex -----	2
25	M-74835	Screw - Switch Mounting -----	2
26	R-24940-2	Switch (2 & 3 Phase Below 250 V.) -----	1
27	R-24940-4	Switch (1 Phase Below 250 V.) -----	1
28	SS-3-26	Switch (2 & 3 Phase Above 250 V.) -----	1
29	R-70190	Gusset - R.H. Table Extension Support -----	1
30	WS-18-8	Washer -----	8
31	WL-4-4	Lock Washer - 3/8" x .136" x .070" -----	4
32	SC-37-73	Fin. Bolt - 3/8"-16 x 1" Hex Hd. -----	4
33	NS-13-25	Full Nut - 3/8"-16 Hex Fin. -----	4
34	R-67259-2	Base Door Assy. -----	1
35	SC-62-50	Fin. Bolt - 1/4"-20 x 5/8" Hex Hd. -----	4
36	WS-22-8	Washer -----	4
37	WL-3-38	Lock Washer - 1/4" x .109" x .062" -----	4
38	SC-10-33	Mach. Screw - #10-24 x 1/2" Truss Hd. -----	4
39	NS-31-14	Stop Nut - #10-24 "Elastic" -----	4
40	M-67319	Clamp - Table -----	2
41	SC-8-9	Mach. Screw - #10-24 x 3/8" Rd. Hd. -----	2
42	NS-9-22	Mach. Nut - #10-24 Hex -----	1
43	M-23274	Knob - Door -----	1
44	M-68176	Clip - Base Door Spring -----	1
45	T-72897	Base Assy. -----	1
46	R-67327	Pan - Meat Scrap -----	1
47	M-71335-2	Foot & Stud Assy. -----	4
48	R-70189	Gusset - L.H. Table Extension Support -----	1
49	SC-36-71	Fin. Bolt - 3/8"-16 x 1-1/4" Hex Hd. -----	4
50	WL-4-4	Lock Washer - 3/8" x .136" x .070" -----	4
51	NS-13-25	Full Nut - 3/8"-16 Hex Fin. -----	4
52	R-70470	Sub-Base - Motor -----	1
53	P-67593	Reinforcement - Base -----	2
54	M-67305	Booster - Motor -----	As Req'd.
55	SC-36-25	Fin. Bolt - 5/16"-18 x 3/4" Hex Hd. -----	4
56	WS-4-25	Washer -----	4
57	WL-3-43	Lock Washer - 5/16" x .117" x .056" -----	4
58	NS-13-11	Full Nut - 5/16"-18 Hex Fin. -----	4
59	S-70349-1	Motor - 1 Ph. 115/230 V. (60 Cy.) -----	1
60	S-70349-2	Motor - 1 Ph. 208 V. (60 Cy.) -----	1
61	S-70349-3	Motor - 1 Ph. 120/240 V. (50 Cy.) -----	1
62	S-70350-1	Motor - 3 Ph. 208/220/440 V. (60 Cy.) -----	1
63	S-70350-2	Motor - 3 Ph. 550 V. (60 Cy.) -----	1
64	S-70350-3	Motor - 3 Ph. 220/380 V. (50 Cy.) -----	1
65	S-67264-2	Panel - Motor Access -----	1
66	SC-10-33	Mach. Screw - #10-24 x 1/2" Truss Hd. -----	4
67	R-67309-2	"V" Pulley - Motor (4.80" O.D.) (Incls. item #69) -----	1
68	R-67309-4	"V" Pulley - Motor (6.20" O.D.) (50 Cy.) (Incls. item #69) -----	1
69	SC-47-32	Set Screw - 5/16"-18 x 5/16" Soc. Hdls. Cup Pt. -----	1
70	R-12430-62	Key -----	1
71	BV-4-8	V-Belt (60 Cy.) -----	1
72	BV-4-15	V-Belt (50 Cy.) -----	1
73	SC-10-33	Mach. Screw - #10-24 x 1/2" Truss Hd. -----	4
74	NS-31-14	Stop Nut - #10-24 "Elastic" -----	4
75	M-67319	Clamp - Table -----	2
	M-78529	Base, Door & Motor Access Panel Sub-Assy. (Incls. items #34, 45 & 65) -----	1



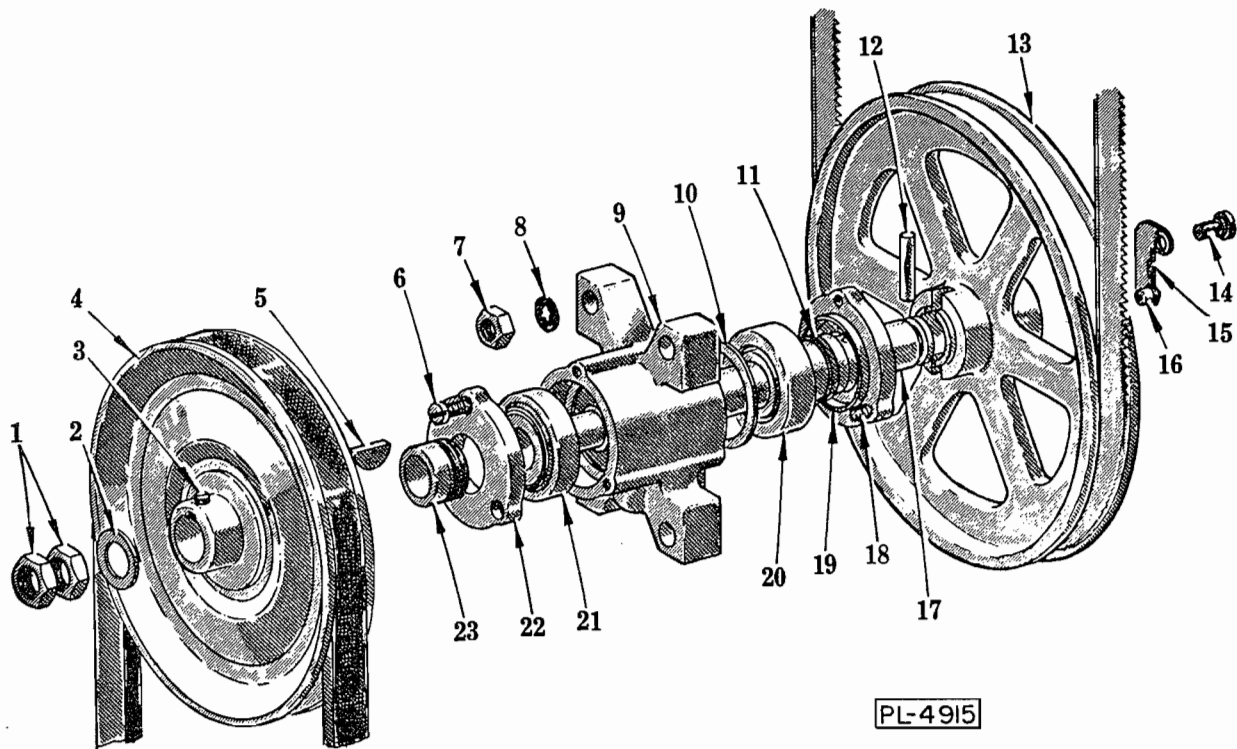

LOWER BEARING CARRIER UNIT

ILLUS. NO.	PART NO.	NAME OF PART	AMT.
1	NS-17-49	Jam Nut - 3/4"-16 Hex Fin. -----	2
2	WS-11-24	Washer -----	1
3	SC-46-50	Set Screw - 5/16"-18 x 1/4" Hcls. Cup Pt. -----	1
4	R-67308	"V" Pulley - Bearing Carrier (8" O.D.) (Incls. item #3) -----	1
5	KW-3-15	Key - #807 Woodruff -----	1
6	SC-12-69	Mach. Screw - 1/4"-20 x 1/2" Fil. Hd. -----	3
7	NS-13-30	Full Nut - 1/2"-13 Hex Fin. -----	8
8	WL-8-31	Lock Washer - 1/2" Int. Shakeproof -----	8
9	R-67207	Carrier - Lower Bearing -----	1
10	RR-6-1	Retaining Ring -----	2
11	M-67307	Quad Ring -----	1
12	M-77813-2	Groov-Pin - Special -----	1
13	R-72362	Flanged Pulley (Blade) Sub-Assy. Unit (Incls. items #14, 15 & 16) --	1
14	M-20851	Screw - Latch -----	1
15	M-20852	Latch -----	1
16	M-24114	Catch - Friction (#8-1/2 Frost) -----	1
17	P-67242	Shaft - Lower Bearing Carrier -----	1
18	SC-12-69	Mach. Screw - 1/4"-20 x 1/2" Fil. Hd. -----	3
19	M-67870	Bearing Cap & Quad Ring Sub-Assy. (Incls. item #11) -----	1
20	BR-2-16	Roller Bearing -----	1
21	BR-2-16	Roller Bearing -----	1
22	P-67203	Cap - Bearing Carrier ("V" Belt Side) -----	1
23	M-67243	Conveyor - Lower Bearing Carrier Grease -----	1
	R-67871	Lower Bearing Carrier Sub-Assy. (Incls. items #6, 9, 10, 17, 18, 19, 20, 21 & 22) -----	1

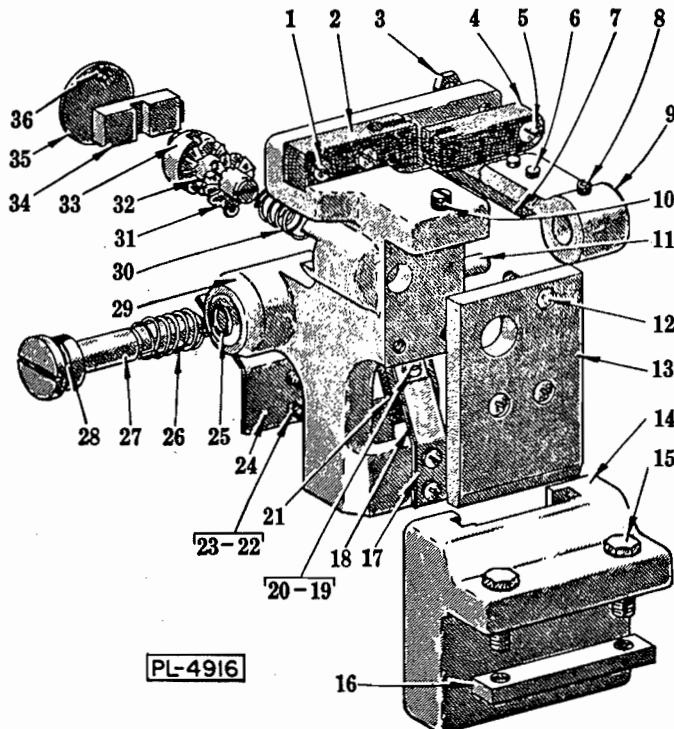

LOWER WIPER AND GUIDE UNIT

ILLUS. NO.	PART NO.	NAME OF PART	AMT.
1	SC-12-81	Mach. Screw - #10-24 x 1" Fil. Hd.	2
2	M-71369	Guide - Saw Blade	1
3	NS-9-23	Mach. Nut - #10-24 Hex	1
4	M-71363	Guard - Saw Blade	1
5	SC-60-72	Mach. Screw - #10-24 x 1-1/4" Rd. Hd.	1
6	SC-10-33	Mach. Screw - #10-24 x 1/2" Truss Hd.	2
7	M-71368	Wiper - Blade Pulley	1
8	SC-75-5	Set Screw - #10-24 x 1/4" Soc. Hdls. Kn. Cup Pt.	1
9	P-71358	Bracket - Scraper Pivot	1
10	SC-63-21	Set Screw - #10-24 x 5/16" Hdls. Flat Pt.	2
11	P-11800-244	Dowel	1
12	SC-12-69	Mach. Screw - 1/4"-20 x 1/2" Fil. Hd.	3
13	P-71372	Slide - Lower Wiper Brkt.	1
14	P-67189	Slideway - Wiper Brkt.	1
15	SC-37-85	Fin. Bolt - 5/16"-18 x 1" Hex Hd.	2
16	M-67702	Plate - Wiper Brkt. Retainer	1
17	M-74612	Spring - Back-up	2
18	M-67185	Spring - Scraper Blade	2
19	SC-21-85	Mach. Screw - #8-32 x 3/16" Rd. Hd.	4
20	WL-6-1	Lock Washer - #8 x .047" x .031"	4
21	M-67184	Blade - Scraper	2
22	SC-21-14	Mach. Screw - #8-32 x 3/8" Rd. Hd.	4
23	WL-6-1	Lock Washer - #8 x .047" x .031"	4
24	M-72443	Shield - Lower Pulley	1
25	R-67500-2	"O" Ring	1
26	M-71364	Spring - Blade Pulley Wiper	1
27	P-71376	Shaft - Lower Wiper Brkt.	1
28	R-67500-7	"O" Ring	1
29	S-71360	Bracket - Lower Wiper	1
30	V-23326	Spring - Adj. Blade Guide	1
31	M-23275	Lock Washer - Adj. Blade (Stat.)	1
32	M-23328	Lock Washer - Adj. Blade (Rot.)	1
33	M-71382	Shaft - Back-Up Block	1
34	M-71373	Block - Blade Back-Up	1
35	M-71377	Retainer - Blade Back-Up Block	1
36	SC-7-24	Mach. Screw - #6-32 x 3/8" Rd. Hd.	2
	S-71378	Lower Wiper & Guide Unit Assy. (Incls. items #1 to 13 inclusive & 17 to 36 inclusive)	1

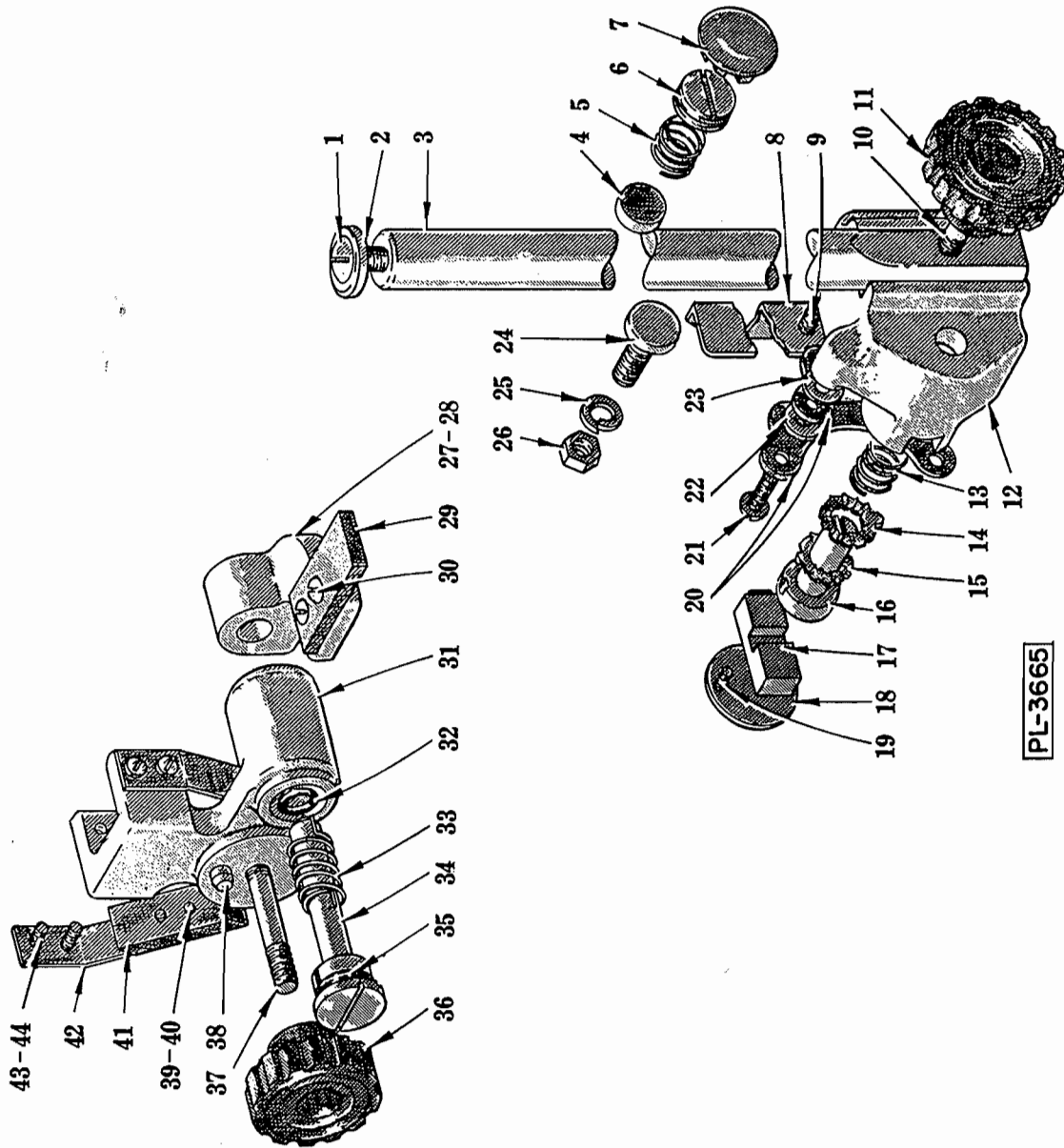

PL-3665

UPPER GUIDE AND WIPER UNIT

## UPPER GUIDE AND WIPER UNIT

ILLUS. PL-3665	PART NO.	NAME OF PART	AMT.
1	SC-53-16	Mach. Screw - 5/16"-18 x 5/8" Truss Hd. -----	1
2	M-69849	Stop - Slide Rod -----	1
3	P-69846	Rod - Upper Blade Guide Slide -----	1
4	M-67239	Shoe - Slide Rod -----	1
5	V-12734	Spring -----	1
6	M-67427	Set Screw - Upper Guide -----	1
7	PB-2-26	Plug Button -----	1
8	P-71397-2	Guard - Upper Guide Blade -----	1
9	SC-10-33	Mach. Screw - #10-24 x 1/2" Truss Hd. -----	2
10	V-21158	Stud - Upper Guide Support -----	1
11	M-67315	Knob -----	1
12	R-71361	Support - Upper Guide -----	1
13	V-23326	Spring - Adj. Blade Guide -----	1
14	M-23275	Lock Washer - Adj. Blade (Stat.) -----	1
15	M-23328	Lock Washer - Adj. Blade (Rot.) -----	1
16	M-71382	Shaft - Back-Up Block -----	1
17	M-71373	Block - Blade Back-Up -----	1
18	M-71377	Retainer - Blade Back-Up Block -----	1
19	SC-7-24	Mach. Screw - #6-32 x 3/8" Rd. Hd. -----	2
20	M-67182	Guide - Blade -----	2
21	SC-10-36	Mach. Screw - #10-24 x 5/8" Truss Hd. -----	2
22	M-67233	Spacer - Blade Guide -----	2
23	M-71449	Shim - Upper Guide Support -----	As Req'd.
24	M-67237	Screw - Slide Rod Adjusting -----	1
25	WL-4-4	Lock Washer - 3/8" x .136" x .070" -----	1
26	NS-17-20	Jam Nut - 3/8"-24 Hex Fin. -----	1
27	P-71359	Bracket - Upper Scraper -----	1
28	SC-75-5	Set Screw - #10-24 x 1/4" Soc. Hdls. Kn. Cup Pt. -----	1
29	M-71368	Wiper - Blade Pulley -----	1
30	SC-10-33	Mach. Screw - #10-24 x 1/2" Truss Hd. -----	2
31	R-71357	Bracket - Upper Wiper -----	1
32	R-67500-2	"O" Ring -----	1
33	M-71364	Spring - Blade Pulley Wiper -----	1
34	P-71376	Shaft -----	1
35	R-67500-7	"O" Ring -----	1
36	M-67315	Knob -----	1
37	V-21158	Stud - Upper Wiper Support -----	1
38	M-67306	Pin - Table Rest -----	1
39	SC-21-85	Mach. Screw - #8-32 x 3/16" Rd. Hd. -----	4
40	WL-6-1	Lock Washer - #8 x .047" x .031" -----	4
41	M-67184	Scraper - Blade -----	2
42	M-67185	Spring - Scraper Blade -----	2
43	SC-21-14	Mach. Screw - #8-32 x 3/8" Rd. Hd. -----	4
44	WL-6-1	Lock Washer - #8 x .047" x .031" -----	4
	P-71398-2	Upper Guide Unit Assy. (Incls. items #8, 9, 10, 12, 13, 14, 15, 16, 17, 18, 19, 20, 21, 22 & 23) -----	1
	R-71379	Upper Wiper Brkt. Assy. (Incls. items #27 to 44 inclusive) -----	1

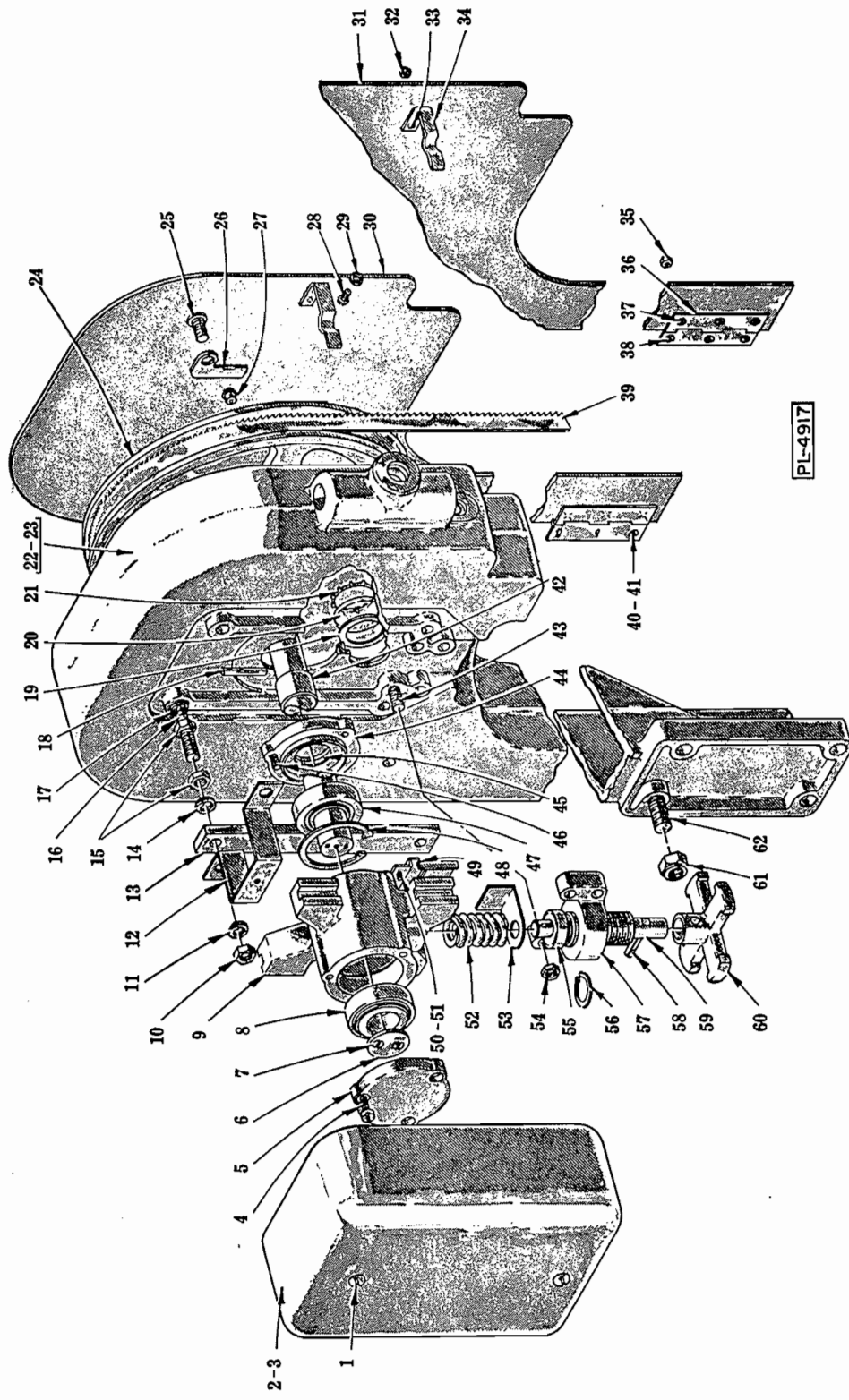

HEAD UNIT

## HEAD UNIT

ILLUS. PL-4917	PART NO.	NAME OF PART	AMT.
1	SC-10-36	Mach. Screw - #10-24 x 5/8" Truss Hd. -----	2
2	R-67151-3	Cover - Upper Bearing Carrier -----	1
*3	R-67151-2	Cover - Upper Bearing Carrier -----	1
4	SC-12-69	Mach. Screw - 1/4"-20 x 1/2" Flt. Hd. -----	3
5	P-67210	Cap - Upper Bearing Carrier -----	1
6	M-67241	Retainer - Upper Bearing -----	1
7	SC-13-46	Mach. Screw - #10-24 x 1/2" Flat Hd. -----	2
8	BR-2-16	Roller Bearing -----	1
9	R-67205	Carrier - Upper Bearing -----	1
10	NS-13-22	Full Nut - 3/8"-16 Hex Fin. -----	4
11	WL-4-4	Lock Washer - 3/8" x .136" x .070" -----	4
12	P-67147	Cover Bracket & Weld Nut Assy. -----	2
13	P-67187	Gib - Upper Bearing Carrier -----	2
14	WL-4-4	Lock Washer - 3/8" x .136" x .070" -----	4
15	NS-13-22	Full Nut - 3/8"-16 Hex Fin. -----	8
16	M-68139	Support Screw - Upper Bearing Carrier -----	4
17	WL-4-4	Lock Washer - 3/8" x .136" x .070" -----	4
18	M-77813-2	Groov-Pin - Special -----	1
19	V-20898	Gasket - Indicator Lens -----	1
20	V-20889	Lens - Indicator -----	1
21	M-23335	Ring - Lens Retaining -----	1
22	T-78535	Head -----	1
*23	T-67154-2	Head -----	1
24	R-72362	Flanged Pulley (Blade) Sub-Assy. Unit (Incls. items #25, 26 & 27) --	1
25	M-20851	Screw - Latch -----	1
26	M-20852	Latch -----	1
27	M-24114	Catch - Friction (#8-1/2 Frost) -----	1
28	SC-21-38	Mach. Screw - 1/4"-20 x 1/2" Rd. Hd. -----	1
29	WL-3-38	Lock Washer - 1/4" x .109" x .062" -----	1
30	R-72236	Door Hinges & Clip Sub-Assy. -----	1
*31	R-67246-2	Door - Head -----	1
*32	NS-27-2	Acorn Nut - #10-24 -----	2
*33	SC-53-5	Mach. Screw - #10-24 x 3/8" Truss Hd. -----	2
*34	M-67180-1	Clip - Head Door Spring -----	1
*35	NS-27-2	Acorn Nut - #10-24 -----	12
*36	M-23271-2	Hinge - Door Head -----	2
*37	SC-53-5	Mach. Screw - #10-24 x 3/8" Truss Hd. -----	6
*38	SC-53-3	Mach. Screw - #10-24 x 3/4" Truss Hd. -----	6
39	P-67447	Blade - Meat Saw -----	1
40	NS-27-2	Acorn Nut - #10-24 -----	6
41	SC-10-44	Mach. Screw - #10-24 x 3/4" Truss Hd. -----	6
42	P-67244	Shaft - Upper Bearing Carrier -----	1
43	SC-10-38	Mach. Screw - 5/16"-18 x 1-3/4" Truss Hd. -----	4
44	M-67870	Bearing Cap & Quad Ring Sub-Assy. (Incls. Item #45) -----	1
45	M-67307	Quad Ring -----	1
46	SC-12-69	Mach. Screw - 1/4"-20 x 1/2" Flt. Hd. -----	3
47	BR-2-16	Roller Bearing -----	1
48	RR-6-1	Retaining Ring -----	2
49	P-67249	Plate - Blade Tension Sight -----	1
50	SC-7-74	Mach. Screw - #10-24 x 3/8" Rd. Hd. -----	2
51	WL-3-20	Lock Washer - #10 x .055" x .040" -----	2
52	M-20867	Spring - Adj. Blade Tension -----	1
53	M-67250	Indicator - Tension -----	1
54	NS-17-6	Jam Nut - 5/16"-18 Hex Fin. -----	2
55	BB-13-1	Thrust Bearing - Nice #603 -----	1
56	RR-4-8	Retaining Ring -----	1
57	P-67204	Nut - Blade Tension Adjusting -----	1
58	RP-2-17	Rollpin - 1/4" dia. x 1" Lg. -----	1
59	M-67240	Screw - Blade Tension Adjusting -----	1
60	P-67190	Wheel - Hand -----	1
61	NS-31-37	Stop Nut - 1/2"-13 "Elastic" -----	4
62	SC-40-33	Cap Screw - 1/2"-13 x 1-1/4" Soc. Flt. Hd. -----	4
	R-67206	Upper Bearing Carrier Assy. (Incls. items #4, 5, 6, 7, 8, 9, 18, 42, 44, 46, 47 & 48) -----	1

\* FOR DELUXE MODEL ONLY

MACHINE SHIPPED WITH TABLE  
AND TABLE EXTENSION REMOVED  
(WILL PASS THROUGH 26" OPENING)

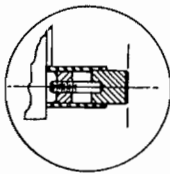

ENLARGED VIEW OF LEG  
SHOWING ADJUSTING SCREW

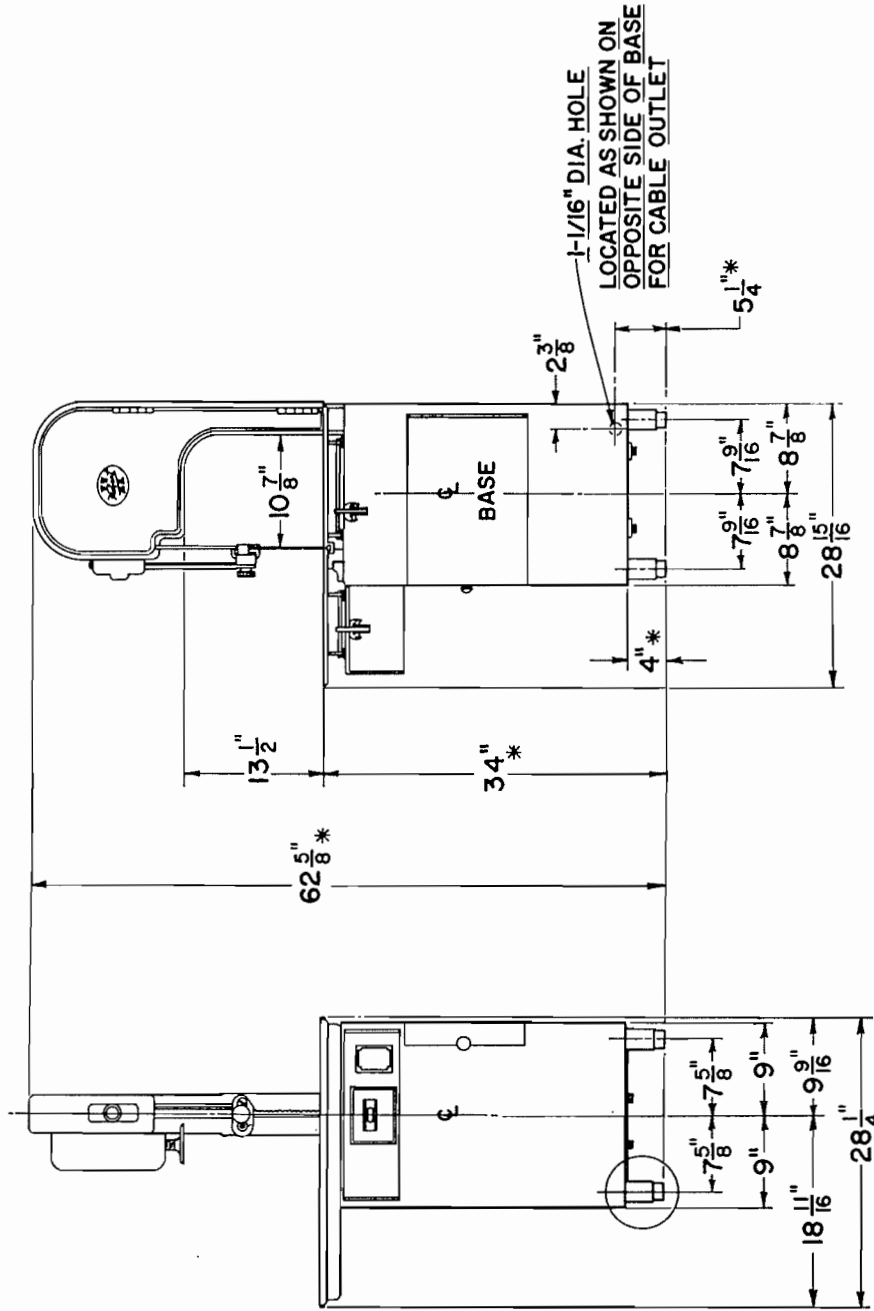

\* THESE DIMENSIONS MAY INCREASE AS MUCH  
AS 1/2" DEPENDING ON LEG ADJUSTMENT

PL-4922

R-70226

INSTALLATION DIAGRAM