

# INSTRUCTION MANUAL

*. . . with Catalog of Replacement Parts*

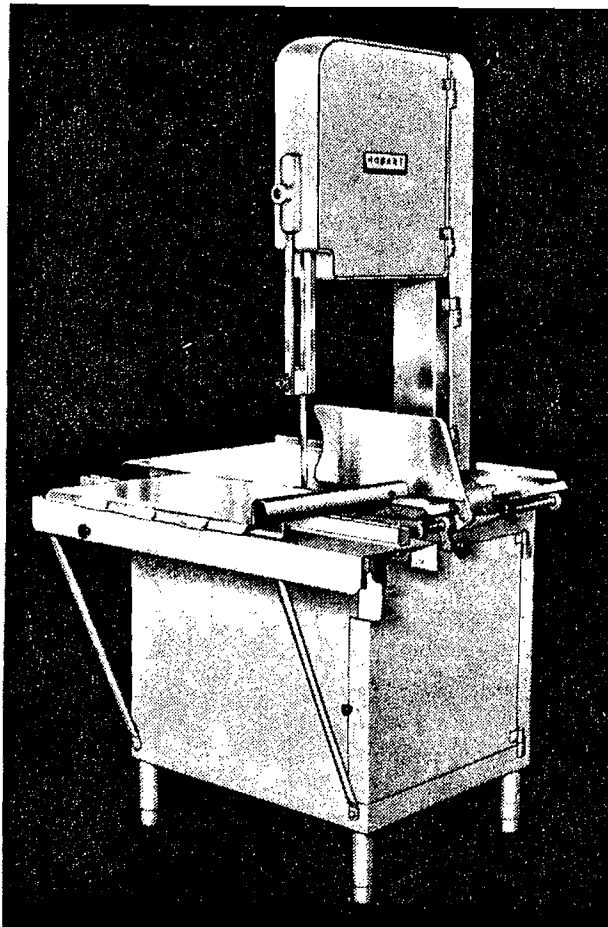

## HOBART

MODEL - 5216 MEAT SAW

M/L #9250 (60 Cy.)

M/L #9580 (50 Cy.)

**HOBART.**

*The World's Oldest and Largest Manufacturer of Computing Scales  
and Food Store, Kitchen, Bakery and Dishwashing Machines*

**THE HOBART MANUFACTURING COMPANY TROY, OHIO**

FORM 4276-F (Revised Feb. 1967) (Supersedes Form 4276-E, Nov. 1966)

- THIS PAGE INTENTIONALLY LEFT BLANK -

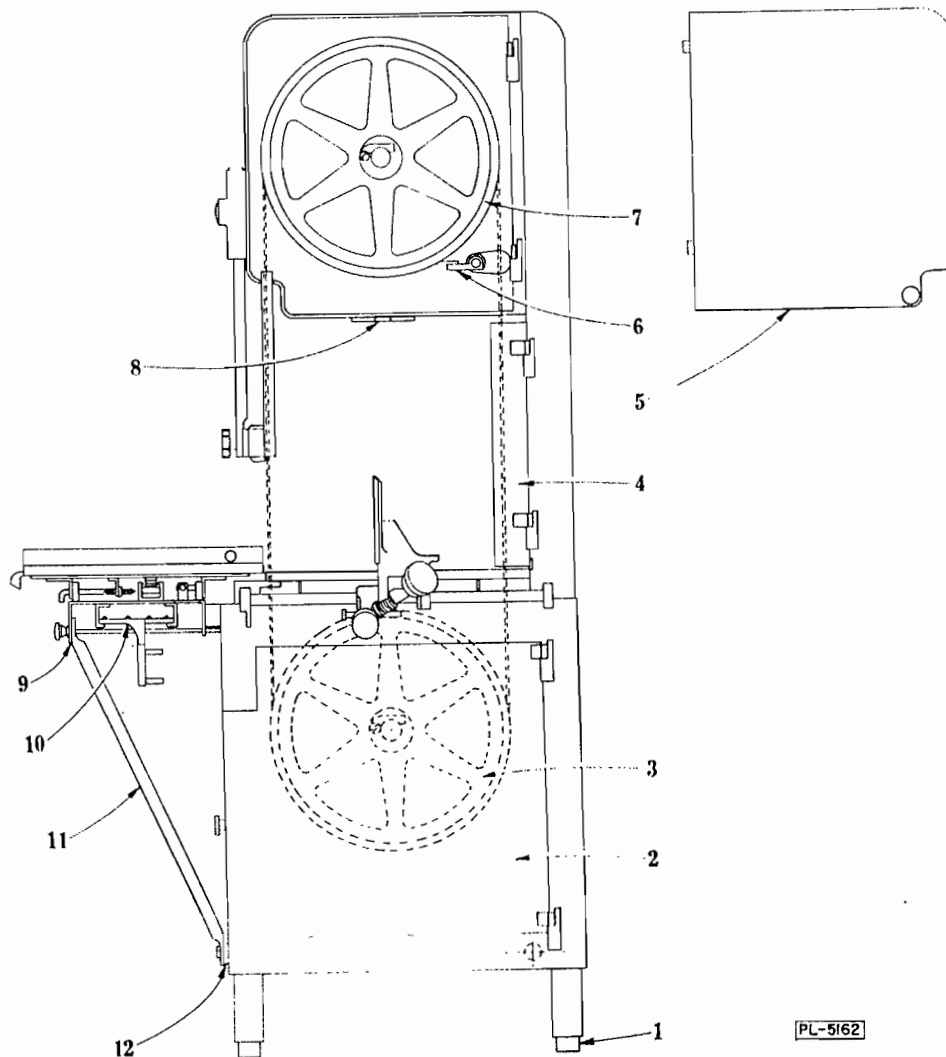

Fig. 1

## Installation, Operation and Care of MODEL 5216 MEAT SAW

### A. UNPACKING

A.1 Remove the shipping box that covers the saw. Next, unpack the following parts that were disassembled for shipping purposes; table assembly, carriage assembly, carriage support assembly, saw blade, front wiper assembly, rear wiper assembly, switch push rod, and feet. The pusher plate is packed in the scrap pan in the base compartment. Remove the four retaining bolts from the underside of the skid.

### B. SETTING UP (Installation)

B.1 Place the machine in the location where it is to be used. Re-assemble the feet (1, Fig. 1). Place a spirit level on top of the base unit and ad-

just the feet in the legs so that the base unit is level from side to side and front to back. Lock feet in place, using set screws furnished.

B.2 Disassemble the six retaining screws and remove the motor access panel on the left hand side of machine. Then using the dowels as locators, bolt the carriage support (9, Fig. 1) to the base. Next assemble the two support braces (11, Fig. 1). Spacers (12, Fig. 1) are used on the lower bolts, and nuts (with lock washers) are assembled on the inside of the base.

B.3 Lower the upper blade pulley (7, Fig. 1) by giving the tension adjustment hand wheel (8, Fig. 1) a few

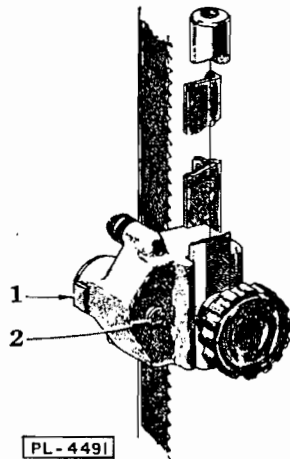

Fig. 2

turns to the left. Open the head door (5, Fig. 1). Remove the blade cover Assy. (4, Fig. 1). Raise the gage plate (1, Fig. 4) to its stopped position. Lower the upper guide unit (Fig. 2) to its lowest position. Place the saw blade over the upper blade pulley (7, Fig. 1) and lower blade pulley (3, Fig. 1). The blade teeth must point to the right and downward when viewed from the front as shown in Fig. 3. If they do not point downward, remove the blade, twist inside out and replace it on the saw. Make sure the blade is properly placed in the upper guide unit (Fig. 2).

Turn the tension adjusting hand wheel (8, Fig. 1) to the right until the figure "3" starts to show in the tension indicator (2, Fig. 4). Give the upper blade pulley a few turns by hand so that the blade centers itself

on the pulleys. Then turn the tension adjusting hand wheel slowly to the right until the indicator registers approximately "4" at eye level. This is the best operating tension for the blade.

NOTE: See section "J" for adjustment of blade back-up blocks.

- B.4 Assemble the rear wiper sub-assy. (7, Fig. 3). The spring catch (6, Fig. 3) will lock it in place. Wipers (8, Fig. 3) should be on both sides of blade.
- B.5 Swing up bakelite guard (1, Fig. 3). Position front wiper assembly, with blade in slot of steel block (5, Fig. 3) and wipers (3, Fig. 3) on both sides of blade. Align assembly into slot of wiper bracket slideway and lower into position. Close bakelite guard (1, Fig. 3).
- B.6 Close head door (5, Fig. 1) (a permanent magnet holds the door in a closed position).
- B.7 With the gage plate (1, Fig. 4) in its raised position (to clear table area), assemble the table (5, Fig. 4). Stand in front of the saw, raise the front edge of the table slightly to clear the saw blade. Move the table to its approximate location so that the right edge of the rear table notch is close to the column. The rear table angle (6, Fig. 4) should be against and inside of the rear table rest angle (7, Fig. 4) for front to rear location of table. Lower the front edge of the table. Next raise the left end of the table approximately 15° and move

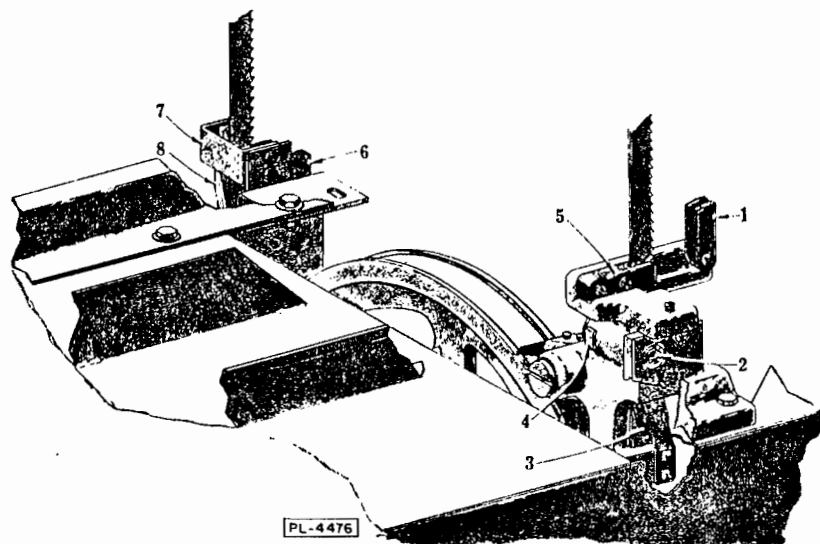

Fig. 3

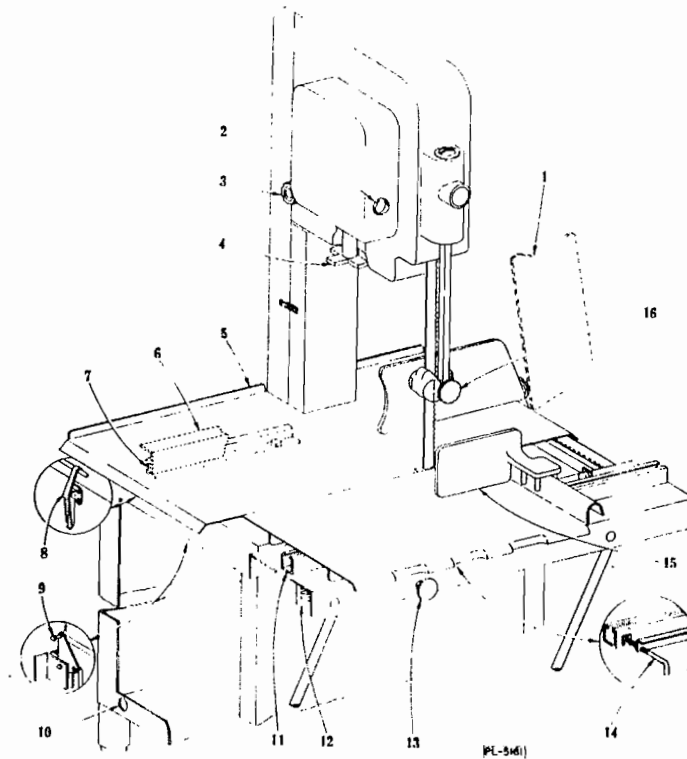

Fig. 4

the table to the right. This will engage the table cross rod with the table catch (Fig. 5) on the base. Lower table into position, aligning front notch with front blade guide. With the table properly positioned, the reinforcing angles of the table nest inside the table rest angles of the base. Lock the table in place with the table clamp (8, Fig. 4). Assemble and latch the blade cover (4, Fig. 1).

- B.8 The carriage may be assembled from either side. Turn the "L" shaped carriage stop (Fig. 6) so that the rubber bumper is toward rear of machine. Align the center bearings of the carriage with the carriage guide (11, Fig. 4). Roll carriage into place. Turn carriage stop (Fig. 6) into stopping position.

- B.9 Assemble the switch pull rod and knob assembly (13, Fig. 4). Insert rod through hole in carriage support, then through bushing in base. Remove cotter pin from flat head pin (9, Fig. 4). Assemble pin (9, Fig. 4) through hole in switch rod and retain pin with cotter pin.

**Switch Replacement:** Switch should always be assembled so that switch

knob (13, Fig. 4) must be pulled to start machine.

**NOTE:** Do not re-assemble access panel until electrical connections have been made.

### C. WIRING

CHECK THE DATA ON THE NAME PLATE (12, Fig. 4) TO MAKE SURE THAT IT AGREES WITH YOUR ELECTRICAL SUPPLY BEFORE CONNECTING TO THE POWER LINE.

Electrical connections should be made by qualified workmen who will observe all applicable Safety Codes and the National Electrical Code.

A hole (10, Fig. 4) in the base is provided for connecting rigid or flexible conduit to the machine. Connect power leads directly to switch. The motor leads are already connected to the switch at the factory.

Be sure to use wire large enough to meet your local code requirements. For proper performance use wire sizes of NOT LESS than #10 gage for 115 V., or #14 gage for 230 V. on single phase models. Use #14 gage for 208, 220, and 440 V. on three phase models. For long runs, between power inlet and saw, use a larger size.

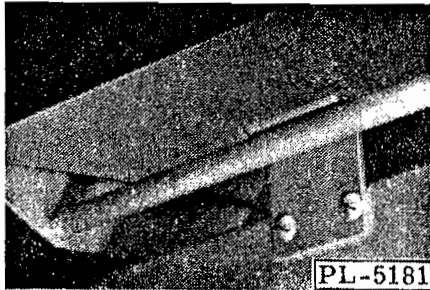

Fig. 5

#### D. SAFETY FEATURES

The Hobart saw is provided with safety devices to give maximum protection to the operator. Keep guards in place at all times.

- D.1 UPPER GUIDE ASSEMBLY (Fig. 2): Keep as low as the size of the work permits.
- D.2 DOORS: Keep all doors closed while machine is running.
- D.3 BUTT-END PUSHER (15, Fig. 4): Use the pusher plate as described in section "F.5" and it will be unnecessary to hold your hand near the running saw blade.
- D.4 GAGE PLATE: The end of the gage plate (1, Fig. 4) is shaped to give maximum support of the product being cut and protection at this critical point, and at the same time facilitate slice removal.
- D.5 SWITCH KNOB (13, Fig. 4): Knob must be pulled to start machine. This eliminates chance starting by accidental bumping of knob.

#### E. LUBRICATION

Very little lubrication is required, because all the high-speed shafts have either roller or ball bearings which are grease packed and will operate a long time without attention.

- E.1 Keep a small amount of grease in the six ball bearing rollers on the carriage.
- E.2 Apply a few drops of oil frequently to the gage plate rack (4, Fig. 7) and work the gage plate assembly back and forth a few times. (See cleaning instructions).
- E.3 For top operating efficiency have your local Hobart service technician check this machine at least once a year.

#### F. OPERATION

F.1 Place the item to be cut on the carriage and turn on the motor switch by pulling switch knob (13, Fig. 4). Stand in front of the machine, leaning lightly against the scalloped front of the carriage, move the carriage to the left, past the saw blade, at a steady and uniform rate. Your left hand will then be free to take away and stack the items as they are cut off. Make it a habit to move your hand around the left side, or back of the saw blade, when reaching for an item — NEVER IN FRONT OF THE TEETH. On the return stroke, pull the item toward you so that it clears the saw blade.

F.2 If a locked carriage is desired; move the carriage to the point where the right end of the carriage is in line with the right end of the table. The carriage lock screw (14, Fig. 4) is then in alignment with the hole in carriage guide. Tighten the lock screw and the carriage is locked in place. With the locked carriage the SAME Safety Procedure of reaching to the left side (or back) of the saw blade when removing or stacking items should ALWAYS be observed.

F.3 When cutting slices of uniform thickness, set the gage plate at the desired position, by turning the adjusting knob (1, Fig. 7). A scale is etched on the table (5, Fig. 4). If the gage plate is not needed and interferes with the work, it may be moved out of the way by either of the two following methods:

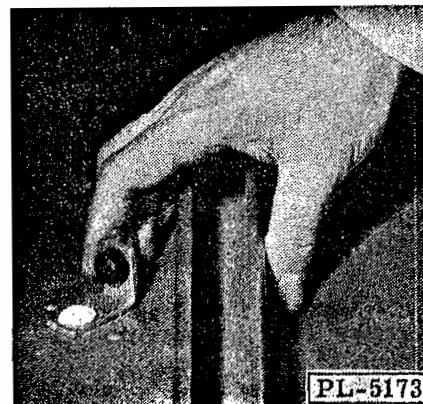

Fig. 6

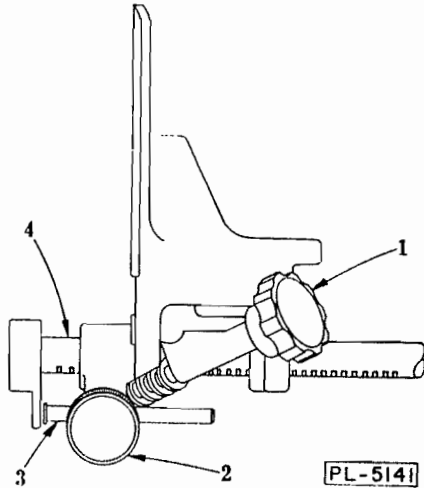

Fig. 7

- (a) Lift the adjusting knob (1, Fig. 7) (to disengage the teeth of the rack (4, Fig. 7)) and slide the gage plate to the rear of the machine.
- (b) Raise the gage plate to a raised position (1, Fig. 4). In this raised position, the gage plate may be slid to any location.
- F.4 The adjustable gaging pin (3, Fig. 7) (after being set), permits the operator to raise the adjusting knob (1, Fig. 7), slide the gage plate back out of the way, then return the gage plate to its original setting (turn knob (1, Fig. 7) clockwise to "snug-up" gage plate and make sure rack teeth are engaged). To set the gaging pin, loosen hand knob (2, Fig. 7) and slide pin against the support stop. Tighten hand knob.
- F.5 Use the pusher plate (15, Fig. 4) to hold the meat against the gage plate when slicing short ends. Dowels in the pusher plate give the necessary alignment with the rolled edge of the carriage. A stop on this rolled edge of the carriage prevents over-travel. By holding the pusher plate with your right hand, your hand will then always be a safe distance from the saw blade. Store the pusher plate on the under side of the carriage support (10, Fig. 1) when not in use.
- G. CLEANING & SANITIZING**
- This saw has been designed for quick and easy cleaning. It is **IMPORTANT** that any machine used for the preparation of food be kept in a clean and sanitary condition. Daily cleaning is recommended. Make sure saw is turned "off" and stopped before starting cleaning operation.
- PROCEDURE:**
- G.1 Turn (at either end) the "L" shaped carriage stop (Fig. 6) and roll off stainless steel carriage.
- G.2 Rotate gage plate to raised position (1, Fig. 4).
- G.3 Open and lift off blade cover (4, Fig. 1).
- G.4 Release table clamp (8, Fig. 4) and remove stainless steel table.
- G.5 Clean the gage plate rack (4, Fig. 7).
- G.6 Turn hand knob (3, Fig. 4) a couple of turns and bump with hand to loosen stud. Remove hand knob. Open and lift off head door (5, Fig. 1). Lift out upper pulley wiper (6, Fig. 1). Clean wiper. Do not replace at this time.
- G.7 Swing up bakelite guard (1, Fig. 3) and lift out front wiper assembly. Clean unit. Do not replace at this time.
- G.8 Press spring catch (6, Fig. 3) to release, then remove rear wiper unit (7, Fig. 3). Clean unit.
- G.9 Open, lift and remove base door (2, Fig. 1).
- G.10 Turn tension adjusting hand wheel (4, Fig. 4) to the left to release blade tension. Remove saw blade and clean in sink.
- G.11 Remove hand knob (16, Fig. 4). Remove upper guide unit (Fig. 2) (with blade already removed or tension released on blade). Clean, lubricate with TASTELESS oil. Do not replace at this time.
- G.12 Remove upper (7, Fig. 1) and lower (3, Fig. 1) blade pulleys by opening latches (1, Fig. 8) clear of shafts and sliding pulleys from the shafts. Clean pulleys in sink and lubricate bore before replacing. **NOTE:** When replacing pulleys, make sure the pulley latches (1, Fig. 8) are properly seated in grooves of shafts. (Upper and lower blade pulleys are interchangeable).
- G.13 All areas are now exposed for easy and thorough cleaning via one of the following procedures:
- G.13.1 HAND CLEANING:**
- G.13.1.1 Materials required:

- G.13.1.1.1 Small nylon bristled brush with (approx.) 12" handle.
- G.13.1.1.2 Small plastic two compartment pail.
- G.13.1.1.3 Clean cloths.
- G.13.1.1.4 Cleaner ("Soilax" All Purpose Cleaner).
- G.13.1.1.5 Sanitizer ("Mikro-Klene" iodophor sanitizer).
- G.13.1.1.6 Plastic spray bottle (for sanitizer).
- G.13.1.2 Procedure (using "Soilax" & "Mikro-Klene"):
- G.13.1.2.1 Add two ounces of "Soilax" All Purpose Cleaner to a gallon of hot water in wash side of two compartment pail.
- G.13.1.2.2 Mix rinse solution by adding two teaspoons of "Mikro-Klene" in one gallon of cool water in rinse side of pail.
- G.13.1.2.3 Brush out large scraps of soil and meat waste.
- G.13.1.2.4 Begin cleaning in the upper pulley area. Brush thoroughly all surfaces being sure to get in corners. Work your way down, being sure to dip the brush frequently into the cleaning solution.
- G.13.1.2.5 Similarly clean the top area (which was covered by the table and the carriage). Work down into the lower pulley housing.
- G.13.1.2.6 Remove the scrap pan and wash separately in sink. Brush clean, the housing and the area around the scrap pan.
- G.13.1.2.7 Rinsing and sanitizing can be done in one of two ways:
- (a) Go over all cleaned surfaces with a cloth soaking wet with "Mikro-Klene" rinse solution.
- (b) Rinse in fresh water and apply "Mikro-Klene" solution via of plastic spray bottle.
- G.13.1.2.8 Allow all surfaces to drain dry and then re-assemble. Do not wipe dry.
- G.13.1.2.9 Protect saw from re-contamination by covering.
- G.13.1.2.10 Rinse the nylon brush thoroughly under running water. Then dip the brush in standard solution of "Mikro-Klene" and allow to drain dry in covered container or wrapped in a freshly laundered towel. Cloth used for rinsing should be sent to laundry, or discarded. Wash out pails.
- G.13.2 HYDRAULIC CLEANING:
- G.13.2.1 Materials required (Economics Laboratory System):
- G.13.2.1.1 Model E "Mikro-Spray" (Economics Laboratory, Inc.).
- G.13.2.1.2 "Mikro-Quat" detergent-sanitizer.
- G.13.2.2 Procedure:
- G.13.2.2.1 Insert an eight ounce bottle of "Mikro-Quat" into the Model E "Mikro-Spray" and turn on the hot water.
- G.13.2.2.2 Spray clean and sanitize both pulley housings and the table area. Be sure to get the hose stream into all corners. Stubborn soil may require a little brushing.
- G.13.2.2.3 Rinse with fresh water from another hose and allow to drain dry. Cover and store as in procedure G.13.1.
- G.13.2.2.4 Either a floor drain or a wet vacuum pick-up machine is required to dispose of the cleaning and rinsing solutions. It may also be desirable to have a portable shower curtain type arrangement to prevent excess splashing into other areas of the work space.
- H. CHANGING SAW BLADES
- H.1 Turn the left hand carriage stop (see section G.1) and move the carriage to the left a few inches beyond the bakelite guard (1, Fig. 3).
- H.2 Raise gage plate (1, Fig. 4) to raised position.
- H.3 Turn tension adjusting hand wheel (4, Fig. 4) to left to release blade tension.
- H.4 Remove blade cover assembly (4, Fig. 1).
- H.5 Release table clamp (8, Fig. 4) and remove table.
- H.6 Open head door (5, Fig. 1).
- H.7 Swing up bakelite guard (1, Fig. 3).
- H.8 Remove saw blade.
- H.9 Assemble new blade. Make sure front and rear lower blade wipers are on both sides of blade.



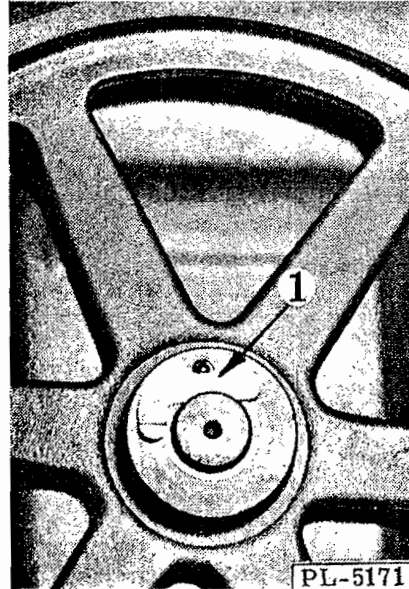

Fig. 8

H.10 Turn the tension adjusting hand wheel (4, Fig. 4) to the right until the edge of the "3" first appears in the window (2, Fig. 4).

H.11 Turn the upper blade pulley (7, Fig. 1) by hand to center the blade.

H.12 Turn the tension adjusting hand wheel to the right until the indicator (2, Fig. 4) registers "4" at eye level.

H.13 Close the lower bakelite guard (1, Fig. 3).

H.14 Re-assemble table and other disassembled parts.

#### J. ADJUSTMENT OF BLADE BACK-UP BLOCK

Special TUNGSTEN CARBIDE blade back-up blocks take the cutting thrust. They are located at the back edge of the

saw blade, in the upper guide (1, Fig. 2) and the front lower wiper unit (4, Fig. 3).

J.1 Adjust the upper back-up block (1, Fig. 2) by turning screw (2, Fig. 2).

J.2 Adjust lower back-up block (4, Fig. 3) by turning screw (2, Fig. 3).

NOTE: Clearance between back-up blocks and blade should be approximately  $1/32$ " (with the saw running without load). ALWAYS check and adjust to this dimension after changing saw blades, as blade widths may vary.

#### K. BLADE REPLACEMENT

Two saw blades are furnished as regular equipment with each machine. Replacement blades are available through all Hobart offices.

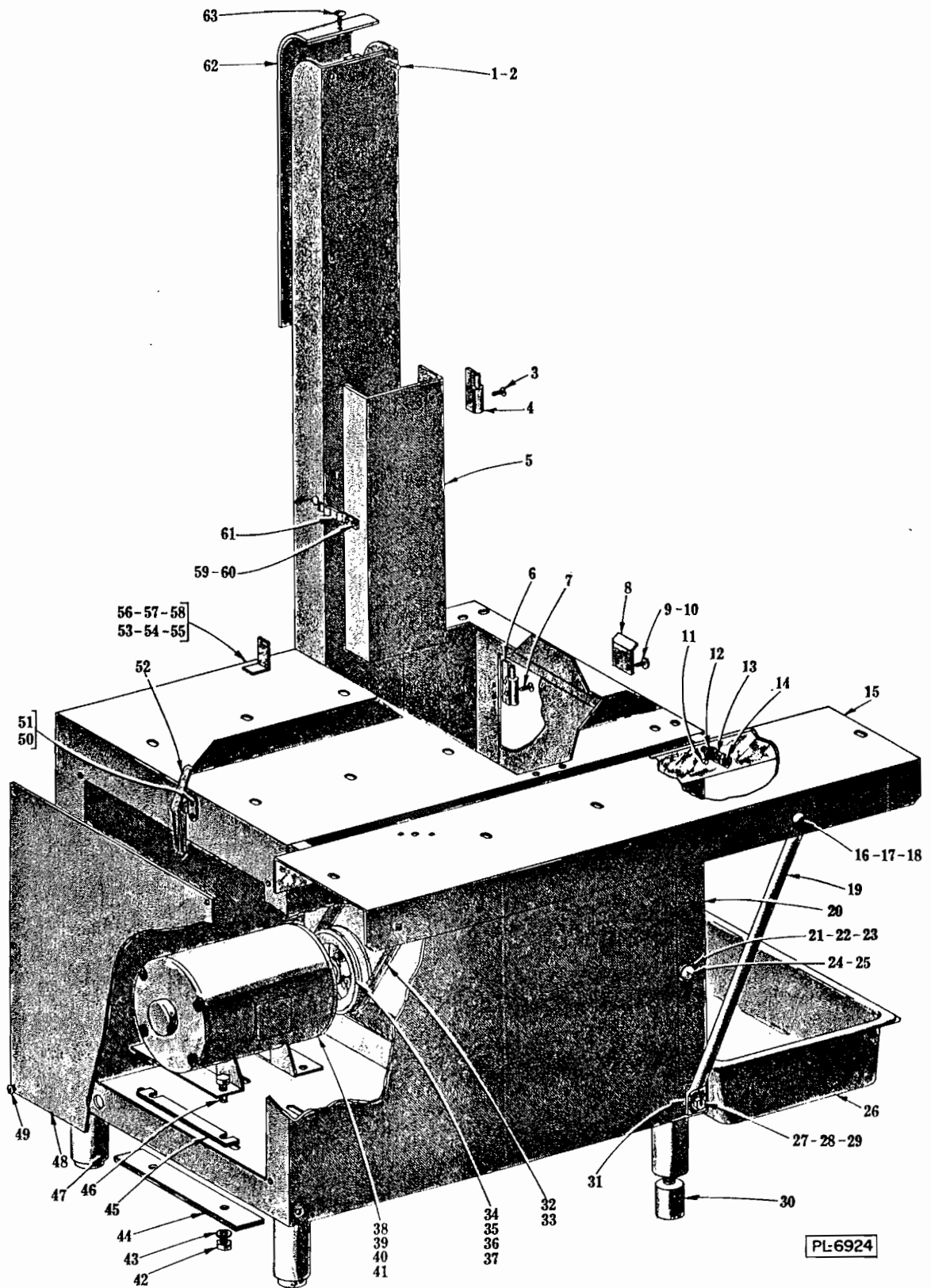

BASE UNIT

## BASE UNIT

ILLUS. PL-6924	PART NO.	NAME OF PART	AMT.
1	SC-36-50	Fin. Bolt - 3/8"-16 x 1/2" Hex Hd. -----	8
2	WL-4-2	Lock Washer - 3/8" x .136" x .070" -----	8
3	SC-20-19	Mach. Screw - #10-32 x 3/4" Phil. Flat Hd. -----	4
4	P-78917	Bracket - Hinge -----	2
5	R-79124	Blade Cover Assy. -----	1
6	P-78917	Bracket - Hinge -----	2
7	SC-13-65	Mach. Screw - #10-32 x 3/4" Flat Hd. -----	4
8	P-77192	Clamp - Stationary Table -----	1
9	SC-10-33	Mach. Screw - #10-24 x 1/2" Truss Hd. -----	2
10	NS-31-14	Stop Nut - #10-24 "Elastic" -----	2
11	M-81339	Dowel -----	2
12	WS-18-8	Washer -----	2
13	WL-4-4	Lock Washer - 3/8" x .136" x .070" -----	2
14	SC-62-43	Fin. Bolt - 3/8"-16 x 3/4" Hex Hd. -----	2
15	S-78062	Carriage Support Sub-Assy. -----	1
16	SC-78-36	Carriage Bolt - 3/8"-16 x 1" -----	2
17	WL-4-4	Lock Washer - 3/8" x .136" x .070" -----	2
18	NS-13-25	Full Nut - 3/8"-16 Hex Fin. -----	2
19	S-78993	Brace - Carriage Support -----	2
20	R-78040	Base Door Sub-Assy. -----	1
21	SC-8-9	Mach. Screw - #10-24 x 3/8" Rd. Hd. -----	1
22	NS-9-22	Mach. Nut - #10-24 Hex -----	1
23	M-68176	Clip - Spring -----	1
24	M-23274	Knob - Door -----	1
25	SC-8-9	Mach. Screw - #10-24 x 3/8" Rd. Hd. -----	1
26	S-71518	Pan - Scrap -----	1
27	SC-62-42	Fin. Bolt - 3/8"-16 x 1" Hex Hd. -----	2
28	WL-4-4	Lock Washer - 3/8" x .136" x .070" -----	2
29	NS-13-25	Full Nut - 3/8"-16 Hex Fin. -----	2
30	M-77217	Foot & Stud Assy. -----	4
31	M-74888	Washer - Shim -----	2
32	BV-3-42	"V" Belt (60 Cy.) -----	1
33	BV-5-11	"V" Belt (50 Cy.) -----	1
34	R-71418-1	"V" Pulley - Motor (5.6" O.D.) (60 Cy.) (Incls. item #36) -----	1
35	R-71418-2	"V" Pulley - Motor (6.6" O.D.) (50 Cy.) (Incls. item #36) -----	1
36	SC-47-32	Set Screw - 5/16"-18 x 5/16" Soc. Hdls. Cup Pt. -----	1
37	R-12430-62	Key -----	1
38	S-79471-1	Motor - 1 Phase, 115/208-230 V. 60 Cy. (Incls. item #37) -----	1
39	S-79472-1	Motor - 3 Phase, 208-220/416-440 V. 60 Cy. (Incls. item #37) -----	1
40	S-79471-2	Motor - 1 Phase, 110/220 V. 50 Cy. (Incls. item #37) -----	1
41	S-79472-3	Motor - 3 Phase, 220/380 V. 50 Cy. (Incls. item #37) -----	1
42	NS-13-25	Full Nut - 3/8"-16 Hex Fin. -----	4
43	WL-4-4	Lock Washer - 3/8" x .136" x .070" -----	4
44	P-78992	Reinforcement - Base -----	2
45	M-67305	Booster - Motor -----	As Req'd
46	SC-36-71	Fin. Bolt - 3/8"-16 x 1-1/4" Hex Hd. -----	4
47	SC-46-98	Set Screw - #10-24 x 1/4" Slotted Hdls. Cup Pt. -----	4
48	R-78043	Panel - Motor Access -----	1
49	SD-9-19	Self-Tapping Screw - #10-32 x 5/16" Phil. Rd. Hd., Type F -----	6
50	SC-10-33	Mach. Screw - #10-24 x 1/2" Truss Hd. -----	4
51	NS-31-14	Stop Nut - #10-24 "Elastic" -----	4
52	P-71437	Clamp - Table -----	1
53	T-78038-1	Base Unit Assy. (all voltages except 115 V.) (Incls. items #6 & 7) -----	1
54	T-78038-2	Base Unit Assy. (115 V. only) (Incls. items #6 & 7) -----	1
55	T-78038-3	Base Unit Assy. (Mag. Starter) (All Voltages Except 115 V.) (Incls. items #6 & 7) -----	1
56	T-78038-4	Base Unit Assy. (Mag. Starter) (115 V. Only) (Incls. items #6 & 7) -----	1
57	T-78038-5	Base Unit Assy. (All voltages except 115 V., 1 Ph.) (Incls. items #6 & 7) -----	1
58	T-78038-6	Base Unit Assy. (115 V., 1 Ph. ONLY) (Incls. items #6 & 7) -----	1
59	SC-10-48	Mach. Screw - #10-24 x 1/4" Truss Hd. -----	2
60	WL-8-12	Lock Washer - #10 Int. Shakeproof -----	2
61	M-68176	Clip - Spring -----	1
62	S-71223	Cover - Column Top -----	1
63	SC-10-33	Mach. Screw - #10-24 x 1/2" Truss Hd. -----	5

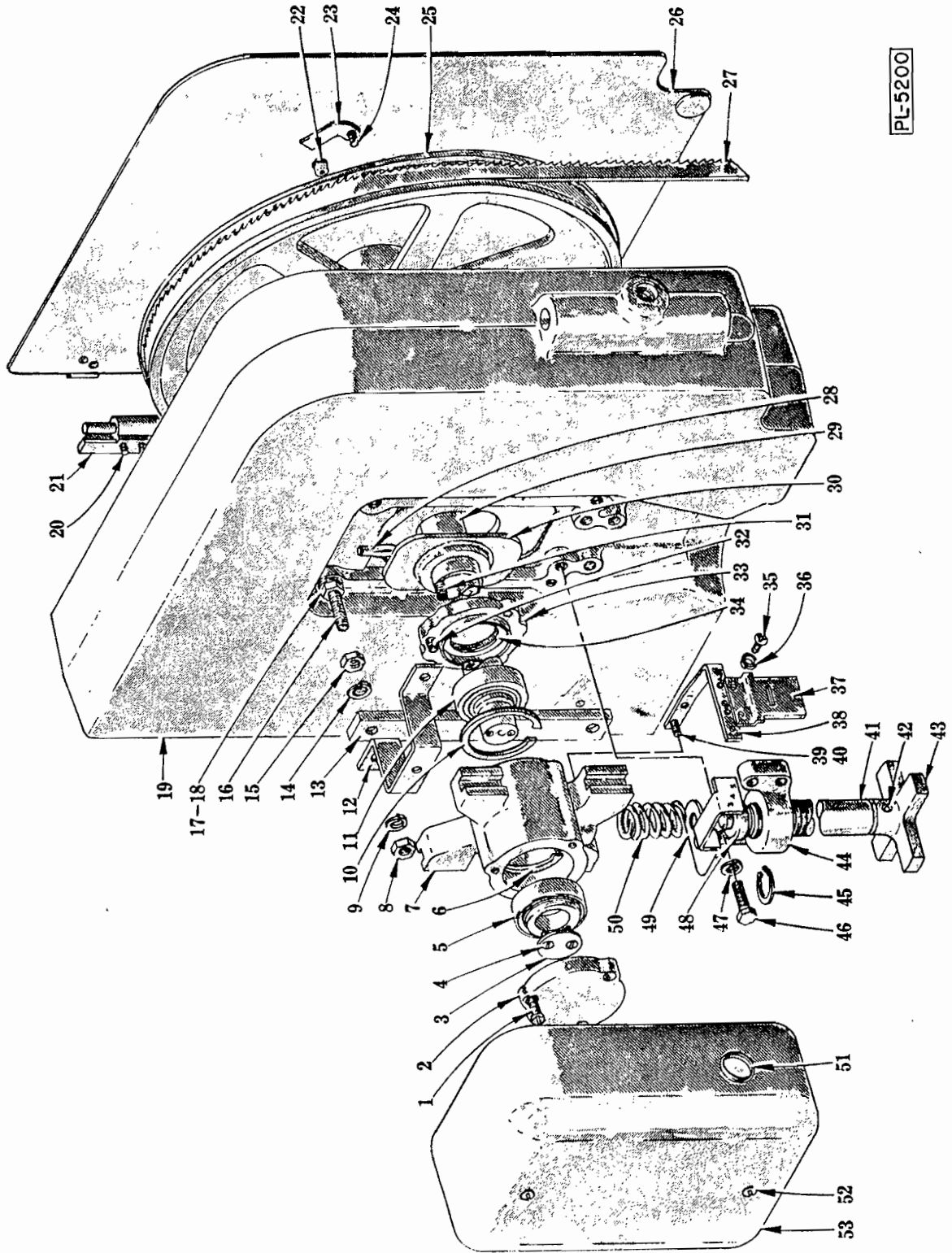

PL-5200

HEAD UNIT

## HEAD UNIT

ILLUS. PL-5200	PART NO.	NAME OF PART	AMT.
1	SC-12-69	Mach. Screw - 1/4"-20 x 1/2" Fil. Hd. -----	3
2	P-67210	Cap - Bearing -----	1
3	M-67241	Retainer - Bearing -----	1
4	SC-13-46	Mach. Screw - #10-24 x 1/2" Flat Hd. -----	2
5	BR-2-16	Roller Bearing -----	1
6	RR-6-1	Retaining Ring -----	1
7	R-71295	Carrier - Upper Bearing -----	1
8	NS-13-22	Full Nut - 3/8"-16 Hex Fin. -----	4
9	WL-4-2	Lock Washer - 3/8" x .136" x .070" -----	4
10	RR-7-1	Retaining Ring -----	1
11	BR-2-20	Roller Bearing -----	1
12	P-67147	Cover Brkt. & Weld Nut Assy. -----	2
13	P-67187	Gib - Upper Brg. Carrier -----	2
14	WL-4-2	Lock Washer - 3/8" x .136" x .070" -----	4
15	NS-13-22	Full Nut - 3/8"-16 Hex Fin. -----	4
16	M-75894	Stud - Upper Bearing Carrier Support -----	4
17	WL-4-2	Lock Washer - 3/8" x .136" x .070" -----	4
18	NS-13-22	Full Nut - 3/8"-16 Hex Fin. -----	4
19	P-75872-1	Head & Magnetic Catch Sub-Assy. -----	1
20	SC-20-15	Mach. Screw - #10-24 x 7/8" Phil. Flat Hd. -----	4
21	P-78917	Bracket - Hinge -----	2
22	M-79686	Catch - Friction -----	1
23	M-20852	Latch -----	1
24	M-20851	Screw - Latch -----	1
25	R-72364	Flanged Pulley (Blade) Sub-Assy. Unit (Incls. items #22, 23 & 24) ..	1
26	S-75806	Door Assy. (Head) -----	1
27	P-71514	Blade - Meat Saw (128" Lg.) -----	1
28	M-77813-1	Groov-Pin - Special -----	1
29	R-71298	Shaft - Upper Bearing Carrier -----	1
30	P-75752	Shield - Bearing Carrier -----	1
31	M-75837	Spring - Detent -----	2
32	SC-12-69	Mach. Screw - 1/4"-20 x 1/2" Fil. Hd. -----	3
33	P-75870	Bearing Carrier Cap & Seal Sub-Assy. (Incls. item #34) -----	1
34	M-71403	Seal - Grease -----	1
35	SC-7-71	Mach. Screw - #10-24 x 1/4" Rd. Hd. -----	2
36	WL-3-22	Lock Washer - #10 x .055" x .040" -----	2
37	P-67249	Plate - Blade Tension Sight -----	1
38	P-75817	Bracket - Tension Indicator -----	1
39	SC-7-74	Mach. Screw - #10-24 x 3/8" Rd. Hd. -----	2
40	WL-3-22	Lock Washer - #10 x .055" x .040" -----	2
41	P-71365	Screw - Blade Tension Adjusting -----	1
42	PG-7-18	Groov-Pin - Type #5, 1/4" x 1" -----	1
43	P-79756	Wheel - Hand -----	1
44	P-75897	Nut - Blade Tension Adjusting -----	1
45	RR-4-8	Retaining Ring -----	1
46	SC-36-28	Fin. Bolt - 5/16"-18 x 1-1/4" Hex Hd. -----	4
47	WL-3-44	Lock Washer - 5/16" x .125" x .078" -----	4
48	BB-13-1	Thrust Bearing - Nice #603 -----	1
49	P-75816	Indicator - Tension -----	1
50	M-20867	Spring - Adj. Blade Tension -----	1
51	M-75656	Window Unit -----	1
52	SC-10-47	Mach. Screw - #10-24 x 1-3/8" Truss Hd. -----	2
53	R-75883	Cover & Window Sub-Assy. (Incls. item #51) -----	1
	R-75842	Upper Bearing Carrier Assy. (Incls. items #1, 2, 3, 4, 5, 6, 7, 10, 11, 29, 32 & 33) -----	1

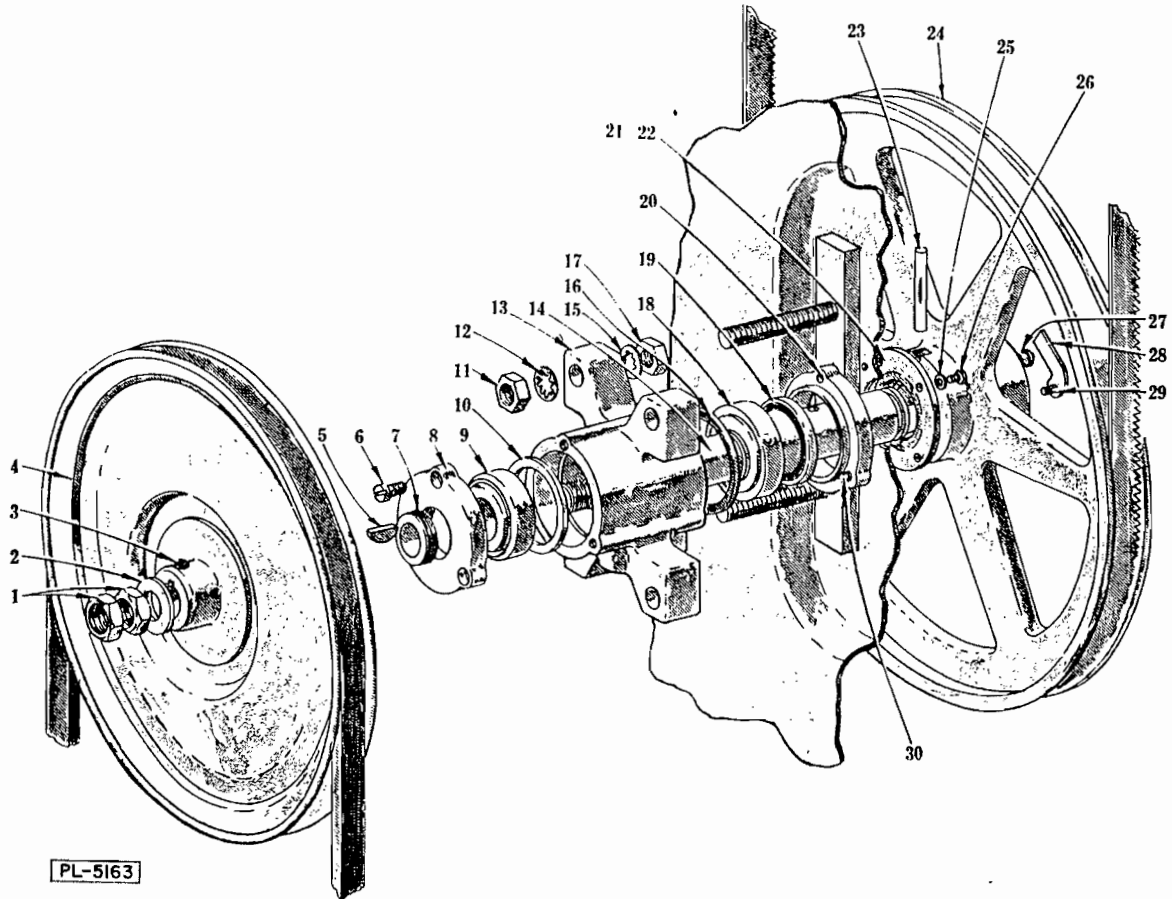

**LOWER BEARING CARRIER UNIT**

ILLUS. PL-5163	PART NO.	NAME OF PART	AMT.
1	NS-17-49	Jam Nut - 3/4"-16 Hex Fin. -----	2
2	WS-11-24	Washer -----	1
3	SC-47-32	Set Screw - 5/16"-18 x 5/16" Soc. Hdls. Cup Pt. -----	1
4	R-74151	"V" Pulley - Brg. Carrier (13" O.D.) (Incls. item #3) -----	1
5	KW-3-15	Key - #807 Woodruff -----	1
6	SC-12-69	Mach. Screw - 1/4"-20 x 1/2" Fil. Hd. -----	3
7	M-79129	Conveyor - Lower Bearing Carrier Grease -----	1
8	P-67203	Cap - Lower Brg. Carrier ("V" Belt Side) -----	1
9	BR-2-16	Roller Bearing -----	1
10	RR-6-1	Retaining Ring -----	1
11	NS-13-30	Full Nut - 1/2"-13 Hex Fin. -----	4
12	WL-8-31	Lock Washer - 1/2" Int. Shakeproof -----	4
13	R-71296	Carrier - Lower Bearing -----	1
14	R-79128	Shaft - Lower Brg. Carrier -----	1
15	WL-8-31	Lock Washer - 1/2" Int. Shakeproof -----	4
16	RR-7-1	Retaining Ring -----	1
17	NS-13-30	Full Nut - 1/2"-13 Hex Fin. -----	4
18	BR-2-20	Roller Bearing -----	1
19	M-71403	Seal - Grease -----	1
20	M-77319	Bearing Cap & Seal Sub-Assy. (Incls. item #19) -----	1
21	M-77510	Washer & Seal Sub-Assy. (Incls. item #22) -----	1
22	M-77511	Seal - Diaphragm -----	1
23	M-77813-1	Groov-Pin - Special -----	1
24	R-72364	Flanged Pulley (Blade) Sub-Assy. Unit (Incls. items #27, 28 & 29) ..	1
25	WS-2-51	Washer -----	4
26	SC-68-12	Mach. Screw - #10-32 x 5/16" Trimmed Hex Hd. -----	4
27	M-79686	Catch - Friction -----	1
28	M-20852	Latch -----	1
29	M-20851	Screw - Latch -----	1
30	SC-12-69	Mach. Screw - 1/4"-20 x 1/2" Fil. Hd. -----	3
	P-79127	Lower Bearing Carrier Sub-Assy. (Incls. items #6, 8, 9, 10, 13, 14, 16, 18, 20 & 30) -----	1

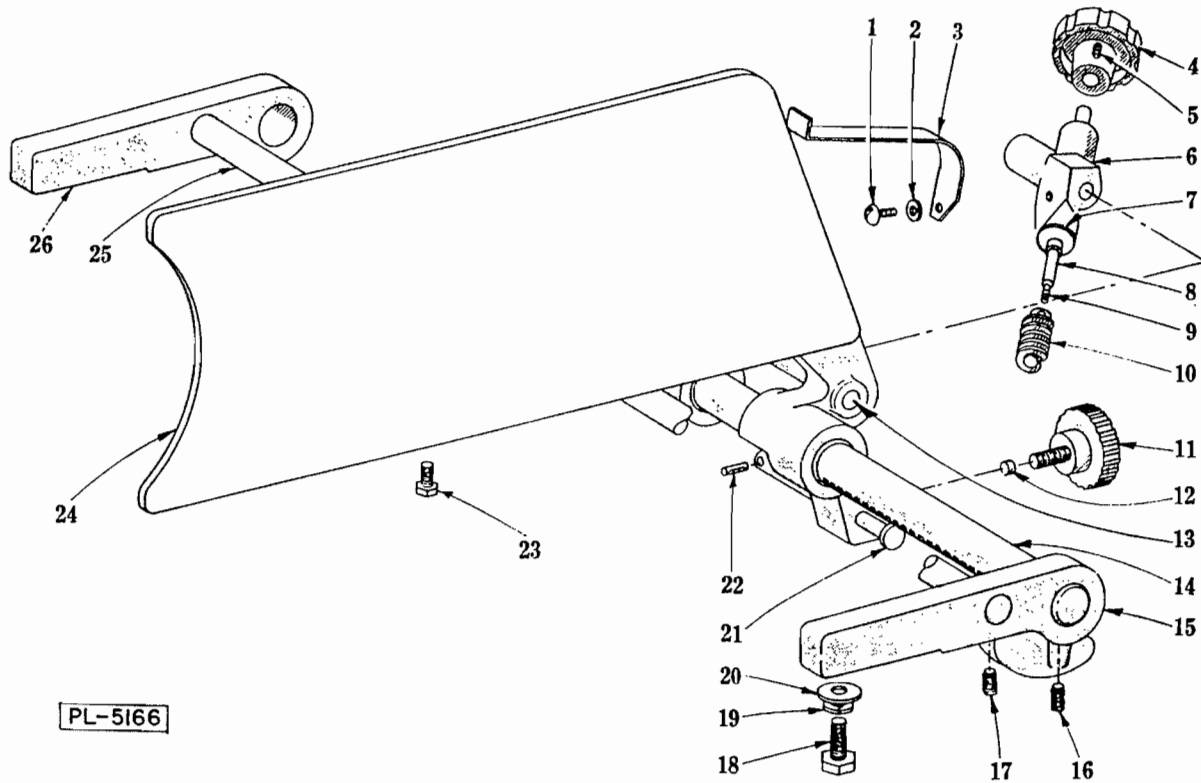

PL-5166

GAGE PLATE UNIT

ILLUS. NO.	PART NO.	NAME OF PART	AMT.
1	SC-9-56	Mach. Screw - #8-32 x 3/8" Rd. Hd.	1
2	WL-3-14	Lock Washer - #8 x .047" x .031"	1
3	P-77848	Spring - Gage Plate	1
4	M-77515	Knob	1
5	SC-47-70	Set Screw - #10-32 x 3/8" Soc. Hdls. Cup Pt.	1
6	M-83481	Worm Bracket & Brg. Sub-Assy.	1
7	WS-18-10	Washer	1
8	M-77843	Shaft - Worm	1
9	PG-7-7	Groov-Pin - Type #5, 1/8" x 7/16"	1
10	M-20887	Worm	1
11	M-78923	Knob & Stud Sub-Assy.	1
12	M-78920	Slug	1
13	M-77235	Pin - Gage Plate	1
14	P-77841-2	Rack - Gage Plate	1
15	R-80433	Bracket - Gage Plate Support (Front)	1
16	SC-47-37	Set Screw - 5/16"-18 x 3/8" Soc. Hdls. Kn. Cup Pt.	2
17	SC-47-37	Set Screw - 5/16"-18 x 3/8" Soc. Hdls. Kn. Cup Pt.	2
18	SC-62-43	Fin. Bolt - 3/8"-16 x 3/4" Hex Hd.	4
19	WL-4-4	Lock Washer - 3/8" x .136" x .070"	4
20	WS-18-9	Washer	4
21	M-85397	Gaging Pin	1
22	PG-7-36	Groov-Pin - Type #5, 7/64" x 7/16"	1
23	M-79155	Fin. Mach. Bolt	1
24	R-77844-2	Gage Plate & Bushing Sub-Assy.	1
25	M-77842	Rod - Gage Plate Stop	1
26	R-77191	Bracket - Gage Plate Support (Rear)	1
	S-77234-2	Gage Plate Assy. (Incls. Items #1 thru 13 inclusive and #21, 22, 23 & 24)	1
	P-77846	Worm Bracket Sub-Assy. (Incls. Items #1 thru 10 inclusive)	1

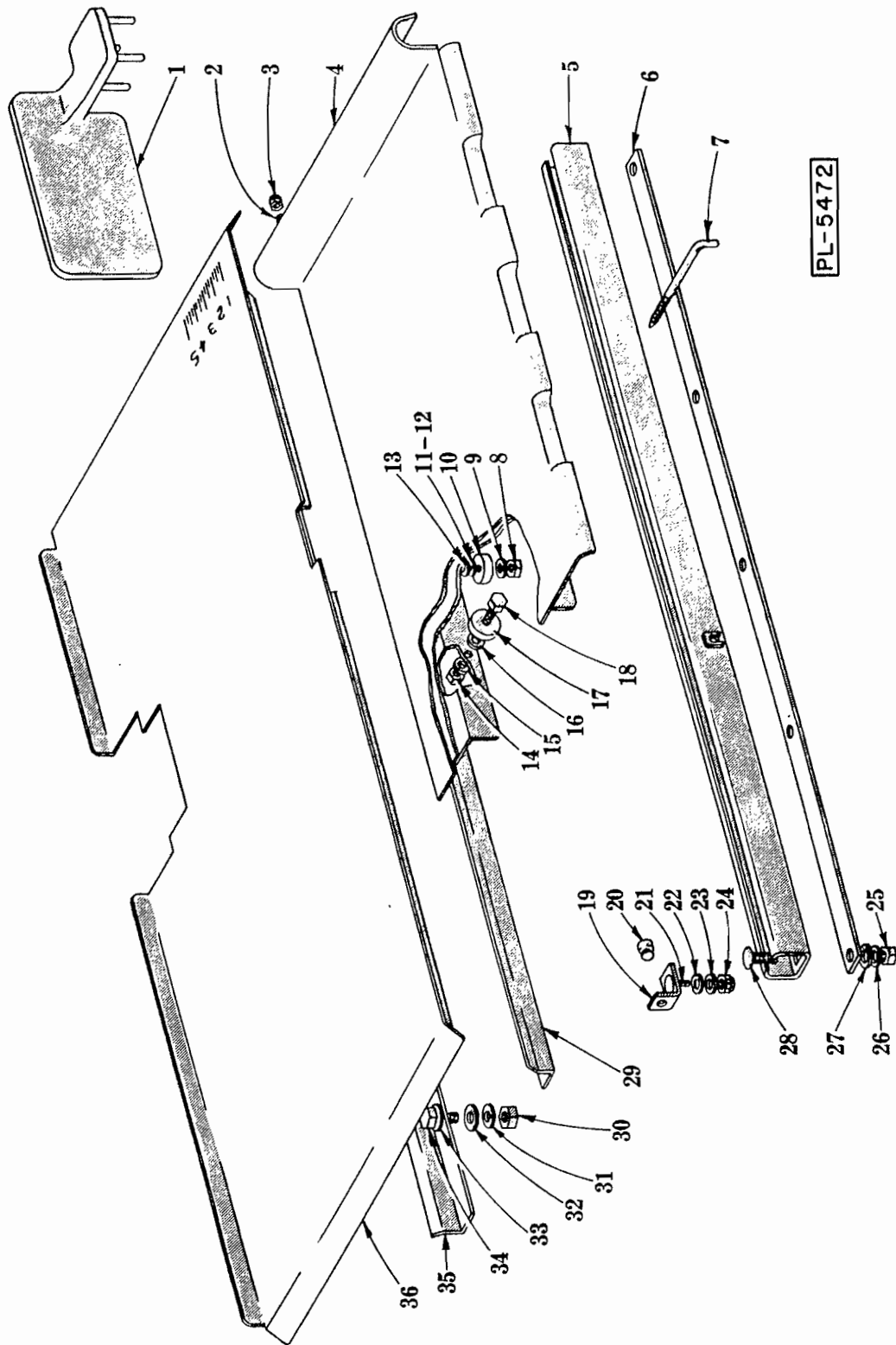

TABLE, CARRIAGE AND TRACK UNIT



## TABLE, CARRIAGE AND TRACK UNIT

ILLUS. PL-5472	PART NO.	NAME OF PART	AMT.
1	P-77576-2	Pusher Plate Assy. -----	1
2	SC-10-48	Mach. Screw - #10-24 x 1/4" Truss Hd. -----	1
3	NS-27-3	Acorn Nut - #10-24 -----	1
4	S-79089	Carriage Sub-Assy. -----	1
5	R-78098	Carriage Guide Sub-Assy. -----	1
6	P-79094	Spacer - Carriage Guide -----	1
7	M-78935-1	Screw - Carriage Lock -----	1
8	NS-13-25	Full Nut - 3/8"-16 Hex Fin. -----	2
9	WL-4-4	Lock Washer - 3/8" x .136" x .070" -----	2
10	BB-8-3	Ball Bearing - Nice #400-24 -----	2
11	WS-18-12	Washer (.010" thk.) -----	As Reqd.
12	M-80698	Shim - Washer (.005" thk.) -----	As Reqd.
13	WS-18-14	Washer (3/64" thk.) -----	2
14	NS-13-25	Full Nut - 3/8"-16 Hex Fin. -----	4
15	WL-4-4	Lock Washer - 3/8" x .136" x .070" -----	4
16	WS-18-5	Washer -----	4
17	BB-8-3	Ball Bearing - Nice #400-24 -----	4
18	SC-37-73	Fin. Bolt - 3/8"-16 x 1" Hex Hd. -----	4
19	P-86049	Stop - Carriage -----	2
20	M-77318	Bumper - Carriage Stop -----	2
21	SC-78-35	Carriage Bolt - 5/16"-18 x 3/4" -----	2
22	WS-18-12	Washer -----	2
23	M-70087	Washer - Spring -----	2
24	NS-32-12	Stop Nut - 5/16"-18 "Flexloc" -----	2
25	NS-13-14	Full Nut - 5/16"-18 Hex Fin. -----	5
26	WL-3-47	Lock Washer - 5/16" x .125" x .078" -----	5
27	WS-17-16	Washer -----	5
28	SC-78-42	Carriage Bolt - 5/16"-18 x 1" -----	5
29	S-78055	Rest - Front Table -----	1
30	NS-13-25	Full Nut - 3/8"-16 Hex Fin. -----	6
31	WL-4-4	Lock Washer - 3/8" x .136" x .070" -----	6
32	WS-18-8	Washer -----	6
33	WS-18-8	Washer -----	6
34	SC-62-42	Fin. Bolt - 3/8"-16 x 1" Hex Hd. -----	6
35	S-78056	Rest - Rear Table -----	1
36	S-78049	Table Assy. -----	1
	M-78093	Carriage Unit Assy. (Incls. items #2, 3, 4, 7, 8, 9, 10, 11, 12, 13, 14, 15, 16, 17 & 18) -----	1

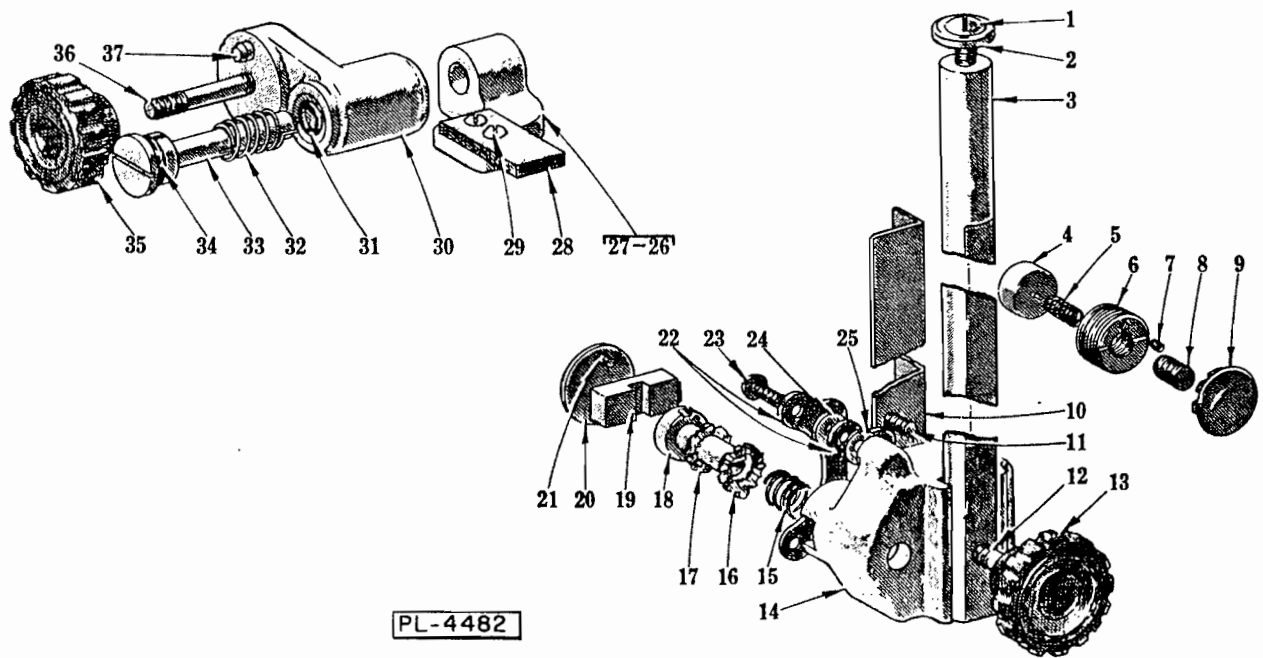

UPPER GUIDE AND PULLEY WIPER UNIT

## UPPER GUIDE AND PULLEY WIPER UNIT

ILLUS. PL-4482	PART NO.	NAME OF PART	AMT.
1	SC-53-16	Mach. Screw - 5/16"-18 x 5/8" Truss Hd. -----	1
2	M-69849	Stop - Slide Rod -----	1
3	P-75869-1	Rod - Upper Blade Guide Slide -----	1
4	M-75865	Shoe - Slide Rod -----	1
5	M-75866	Spring - Slide Rod Adjusting -----	1
6	M-75864	Screw - Slide Rod Adjusting -----	1
7	SC-47-74	Set Screw - #8-32 x 1/4" Soc. Hdls., Cup Pt. -----	1
8	SC-63-33	Set Screw - 3/8"-16 x 3/8" Hdls. Flat Pt. -----	1
9	PB-2-26	Plug Button -----	1
10	P-71397-1	Guard - Upper Guide Blade -----	1
11	SC-10-33	Mach. Screw - #10-24 x 1/2" Truss Hd. -----	2
12	V-21158	Stud - Upper Guide Support -----	1
13	M-67315	Knob -----	1
14	R-71361	Support - Upper Guide -----	1
15	V-23326	Spring - Back-Up Block -----	1
16	M-23275	Lock Washer - Back-Up Block (Stat.) -----	1
17	M-23328	Lock Washer - Back-Up Block (Rot.) -----	1
18	M-71382	Shaft - Back-Up Block -----	1
19	M-71373	Block - Blade Back-Up -----	1
20	M-71377	Retainer - Blade Back-Up Block -----	1
21	SC-7-24	Mach. Screw - #6-32 x 3/8" Rd. Hd. -----	2
22	M-67182	Guide - Blade -----	2
23	SC-10-36	Mach. Screw - #10-24 x 5/8" Truss Hd. -----	2
24	WS-2-51	Washer - Blade Guide Spacer -----	2
25	M-71449-2	Shim - Upper Guide Support -----	As Req'd.
26	P-71359	Bracket - Upper Scraper -----	1
27	SC-75-5	Set Screw - #10-24 x 1/4" Soc. Hdls., Kn. Cup Pt. -----	1
28	M-71368	Wiper - Blade Pulley -----	1
29	SC-10-33	Mach. Screw - #10-24 x 1/2" Truss Hd. -----	2
30	P-75025	Bracket - Upper Pulley Wiper -----	1
31	R-67500-2	"O" Ring -----	1
32	M-71364	Spring - Blade Pulley Wiper -----	1
33	P-71376	Shaft -----	1
34	R-67500-7	"O" Ring -----	1
35	M-67315	Knob -----	1
36	M-71362	Stud - Upper Wiper Support -----	1
37	M-67306	Pin - Table Rest -----	1
	M-71449-2	Shim (Use with item #22) -----	As Req'd.
	P-71398-1	Upper Guide Unit Assy. (Incls. items #10, 11, 12, 14, 15, 16, 17, 18, 19, 20, 21, 22, 23, 24 & 25) -----	1
	P-75031-2	Upper Pulley Wiper Assy. (Incls. items #26 thru 37 inclusive) ----	1

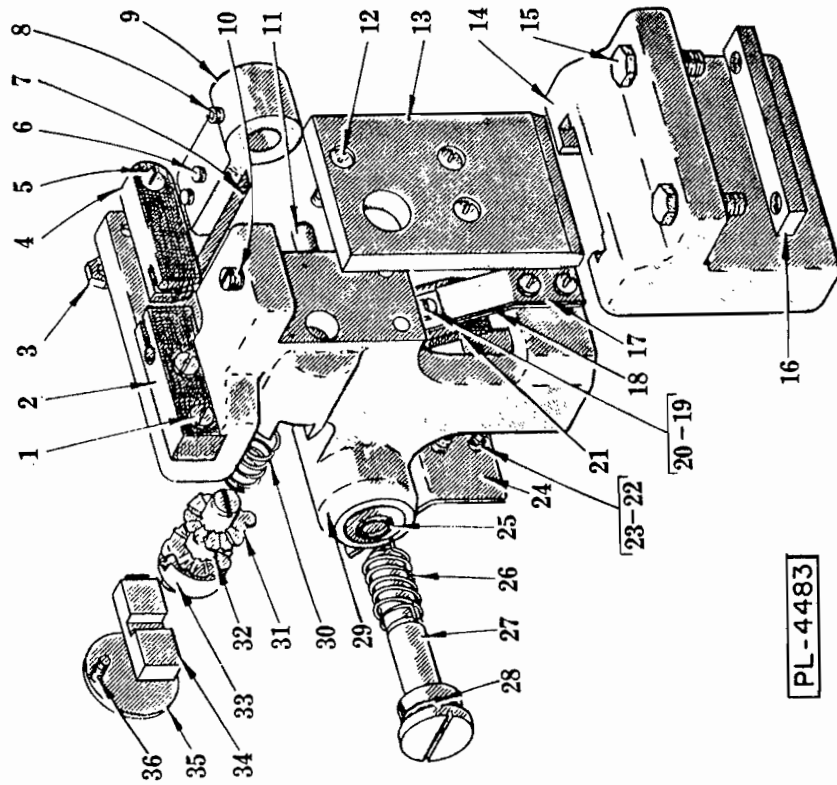

PL-4483

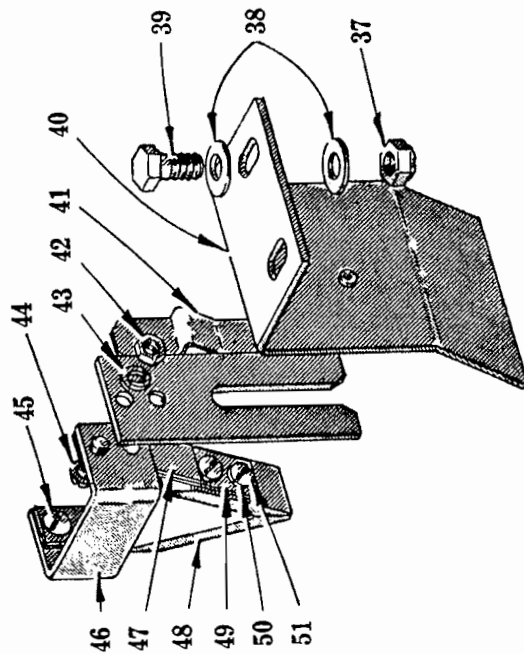

LOWER WIPERS AND GUIDE UNIT

## LOWER WIPERS AND GUIDE UNIT

ILLUS. PL-4483	PART NO.	NAME OF PART	AMT.
1	SC-12-81	Mach. Screw - #10-24 x 1" Fil. Hd. -----	2
2	M-83758-1	Guide - Saw Blade -----	1
3	NS-9-23	Mach. Nut - #10-24 Hex -----	1
4	M-71363	Guard - Saw Blade -----	1
5	SC-60-72	Mach. Screw - #10-24 x 1-1/4" Rd. Hd. -----	1
6	SC-10-33	Mach. Screw - #10-24 x 1/2" Truss Hd. -----	2
7	M-71368	Wiper - Blade Pulley -----	1
8	SC-75-5	Set Screw - #10-24 x 1/4" Soc. Hdls., Kn. Cup Pt. -----	1
9	P-71358	Bracket - Scraper Pivot -----	1
10	SC-63-21	Set Screw - #10-24 x 5/16" Hdls. Flat Pt. -----	2
11	P-11800-244	Dowel -----	1
12	SC-12-42	Mach. Screw - 1/4"-20 x 1/2" Fil. Hd. -----	3
13	P-71372	Slide - Lower Wiper Brkt. -----	1
14	P-67189	Slideway - Wiper Brkt. -----	1
15	SC-37-85	Fin. Bolt - 5/16"-18 x 1" Hex Hd. -----	2
16	M-67702	Plate - Wiper Brkt. Retainer -----	1
17	M-74612	Spring - Back-Up -----	2
18	M-67185	Spring - Blade Scraper -----	2
19	SC-21-85	Mach. Screw - #8-32 x 3/16" Rd. Hd. -----	4
20	WL-6-1	Lock Washer - #8 x .047" x .031" -----	4
21	M-67184	Scraper - Blade -----	2
22	SC-21-14	Mach. Screw - #8-32 x 3/8" Rd. Hd. -----	4
23	WL-6-1	Lock Washer - #8 x .047" x .031" -----	4
24	M-72443	Shield - Lower Pulley -----	1
25	R-67500-2	"O" Ring -----	1
26	M-71364	Spring - Blade Pulley Wiper -----	1
27	P-71376	Shaft - Lower Wiper Brkt. -----	1
28	R-67500-7	"O" Ring -----	1
29	S-71360	Bracket - Lower Wiper -----	1
30	V-23326	Spring - Back-Up Block -----	1
31	M-23275	Lock Washer - Back-Up Block (Stat.) -----	1
32	M-23328	Lock Washer - Back-Up Block (Rot.) -----	1
33	M-71382	Shaft - Back-Up Block -----	1
34	M-71373	Block - Blade Back-Up -----	1
35	M-71377	Retainer - Blade Back-Up Block -----	1
36	SC-7-24	Mach. Screw - #6-32 x 3/8" Rd. Hd. -----	2
37	NS-31-19	Stop Nut - 1/4"-20 "Elastic" -----	2
38	WS-3-45	Washer -----	4
39	SC-41-1	Fin. Bolt - 1/4"-20 x 3/4" Hex Hd. -----	2
40	M-75304	Rear Wiper Brkt. & Slide Stud Sub-Assy. -----	1
41	M-75307	Stop Spring & Rear Wiper Slide Sub-Assy. -----	1
42	NS-11-12	Mach. Nut - #8-32 Hex -----	4
43	WL-6-1	Lock Washer - #8 x .047" x .031" -----	4
44	SC-21-92	Mach. Screw - #8-32 x 7/16" Rd. Hd. -----	2
45	SC-21-91	Mach. Screw - #8-32 x 5/16" Rd. Hd. -----	2
46	M-75310	Support - Rear Wiper Scraper -----	1
47	M-74612	Spring - Back-Up -----	2
48	M-67184	Scraper - Blade -----	2
49	M-67185	Spring - Scraper Blade -----	2
50	WL-6-1	Lock Washer - #8 x .047" x .031" -----	4
51	SC-21-85	Mach. Screw - #8-32 x 3/16" Rd. Hd. -----	4
	S-71378	Lower Wiper & Guide Unit Assy. (Incls. items #1 thru 13 inclusive & items #17 thru 36 inclusive) -----	1
	P-75303	Rear Wiper Sub-Assy. (Incls. items #40 thru 51 inclusive) -----	1

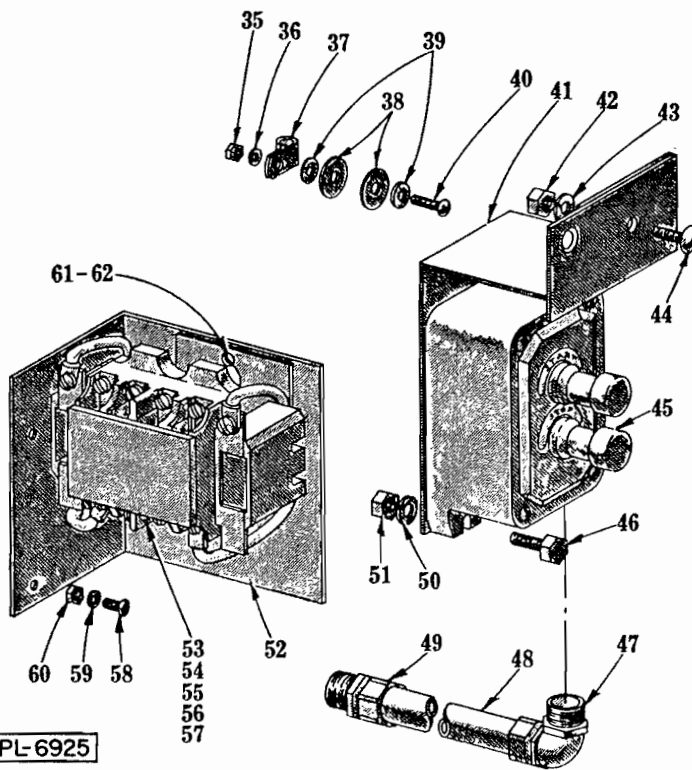
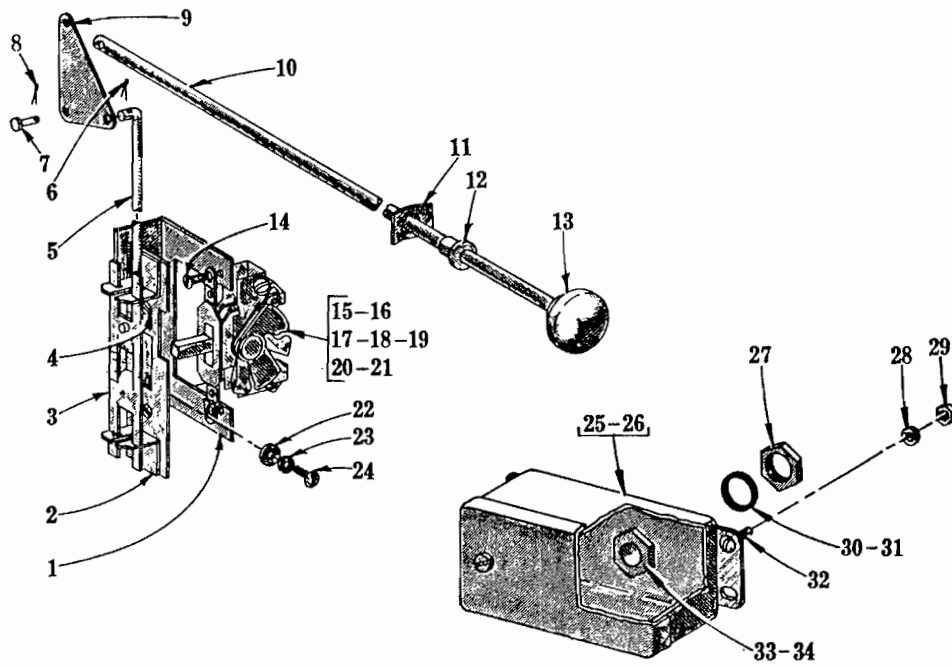

PL-6925

SWITCH UNIT

SWITCH UNIT

ILLUS. PL-6925	PART NO.	NAME OF PART	AMT.
1	P-78902	Bracket - Switch Mounting	1
2	M-78901	Yoke Guide & Track Assy.	1
3	M-60365	Yoke - Switch Operating	1
4	M-74835	Screw - Switch Mounting	2
5	M-78091	Rod - Switch	1
6	PC-3-16	Cotter Pin - 1/16" x 3/8"	1
7	M-78837	Pin - Flat Hd.	2
8	PC-3-16	Cotter Pin - 1/16" x 3/8"	2
9	M-78832	Lever - Pivot	1
10	M-78833-3	Rod - Switch (Upper)	1
11	M-80540	Speed Nut	1
12	M-80538	Bushing	1
13	M-78940	Knob	1
14	M-74835	Screw - Switch Mounting	2
15	P-87711-99-4	Switch (1 Ph., below 250 V.)	1
16	P-87711-99-2	Switch (3 Ph., below 250 V.)	1
17	P-87711-57-1	Switch (3 Ph., above 250 V.)	1
18	P-87810-18-2	Switch - Manual (Thermal Overload) (110-220 V., 1 Ph.)	1
19	P-87810-26-1	Switch - Manual (Thermal Overload) (440 V., 3 Ph.)	1
20	*	Heater Element - Manual Starter (Give Elec. Spec. & Mach. Model)	As Req'd.
21	M-70262	Insulator - Starter (Use with Manual Starter P-87810-26-1)	1
22	WS-2-51	Washer	2
23	WL-3-20	Lock Washer - #10 x .055" x .040"	2
24	SC-8-9	Mach. Screw - #10-24 x 3/8" Rd. Hd.	2
**25	P-86116-1	Box - Junction (All voltages except 115 V., 1 Ph.)	1
**26	P-86116-2	Box - Junction (115 V., 1 Ph. ONLY)	1
**27	FE-6-7	Lock Nut - 1/2" Cnd.	1
**28	WL-3-20	Lock Washer - #10 x .055" x .040"	2
**29	NS-9-30	Mach. Nut - #10-32 Hex	2
**30	R-67500-9	"O" Ring (All voltages except 115 V., 1 Ph.)	1
**31	R-67500-11	"O" Ring (115 V., 1 Ph. ONLY)	1
**32	SC-8-41	Mach. Screw - #10-32 x 1/2" Rd. Hd.	2
**33	M-63849-1	Nipple - Conduit (Use with P-86116-1)	1
**34	FE-2-33	Connector - Straight (3/4" Male Thd. x 3/4" Flex. Cnd.) (Use with P-86116-2)	1
<b>MAGNETIC STARTER</b>			
35	NS-9-22	Mach. Nut - #10-24 Hex	3
36	WL-3-20	Lock Washer - #10 x .055" x .040"	3
37	M-78752-4	Clamp	3
38	WS-3-45	Washer (7/8" O.D.)	2
39	WS-2-51	Washer (1/2" O.D.)	2
40	SC-9-25	Mach. Screw - #10-24 x 5/8" Rd. Hd.	3
41	P-78092	Mounting Bracket Sub-Assy.	1
42	NS-13-2	Full Nut - 1/4"-20 Hex Fin.	1
43	WL-3-38	Lock Washer - 1/4" x .109" x .062"	1
44	SC-9-42	Mach. Screw - 1/4"-20 x 5/8" Rd. Hd.	1
45	R-78558	Station - Push Button	1
46	SC-37-87	Fin. Bolt - 1/4"-20 x 1" Hex Hd.	2
47	FE-6-37	Ell - 90° Short (1/2" Male Thd. x 1/2" Thinwall)	1
48	P-67572-38	Conduit - 1/2" x 6-1/2" (Thinwall)	1
49	FE-6-45	Connector - Straight (1/2" Male Thd. x 1/2" Thinwall)	1
50	WL-3-38	Lock Washer - 1/4" x .109" x .062"	2
51	NS-13-2	Full Nut - 1/4"-20 Hex Fin.	2
52	R-78166	Bracket - Starter Mounting	1
53	P-87712-25-1	Starter - Magnetic (208-230 V., 60 Cy., 1 Ph.) (Less Elements)	1
54	P-87712-21-1	Starter - Magnetic (208-220 V., 60 Cy., 3 Ph.) (Less Elements)	1
55	P-87712-14-1	Starter - Magnetic (440 V., 60 Cy., 3 Ph.) (Less Elements)	1
56	P-87712-14-2	Starter - Magnetic (550 V., 60 Cy., 3 Ph.) (Less Elements)	1
57	*	Heater Element - Magnetic Starter (Give Elec. Spec. & Mach. Model)	A Req'd.
58	SC-8-9	Mach. Screw - #10-24 x 3/8" Rd. Hd.	2
59	WL-3-20	Lock Washer - #10 x .055" x .040"	2
60	NS-9-22	Mach. Nut - #10-24 Hex	3
61	SC-9-56	Mach. Screw - #8-32 x 3/8" Rd. Hd.	3
62	WL-7-7	Lock Washer - #8 Ext. Shakeproof	3

\* Hobart service technician to use Starter Element Part No. as listed on Starter Parts Sheet.

\*\* Use with Manual Overload Starter.

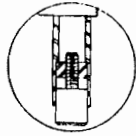

ENLARGED VIEW OF LEG  
SHOWING ADJUSTING FOOT

MACHINE IS PARTIALLY DISASSEMBLED  
FOR SHIPMENT. CRATED MACHINE WILL  
PASS THRU A 33° OPENING.

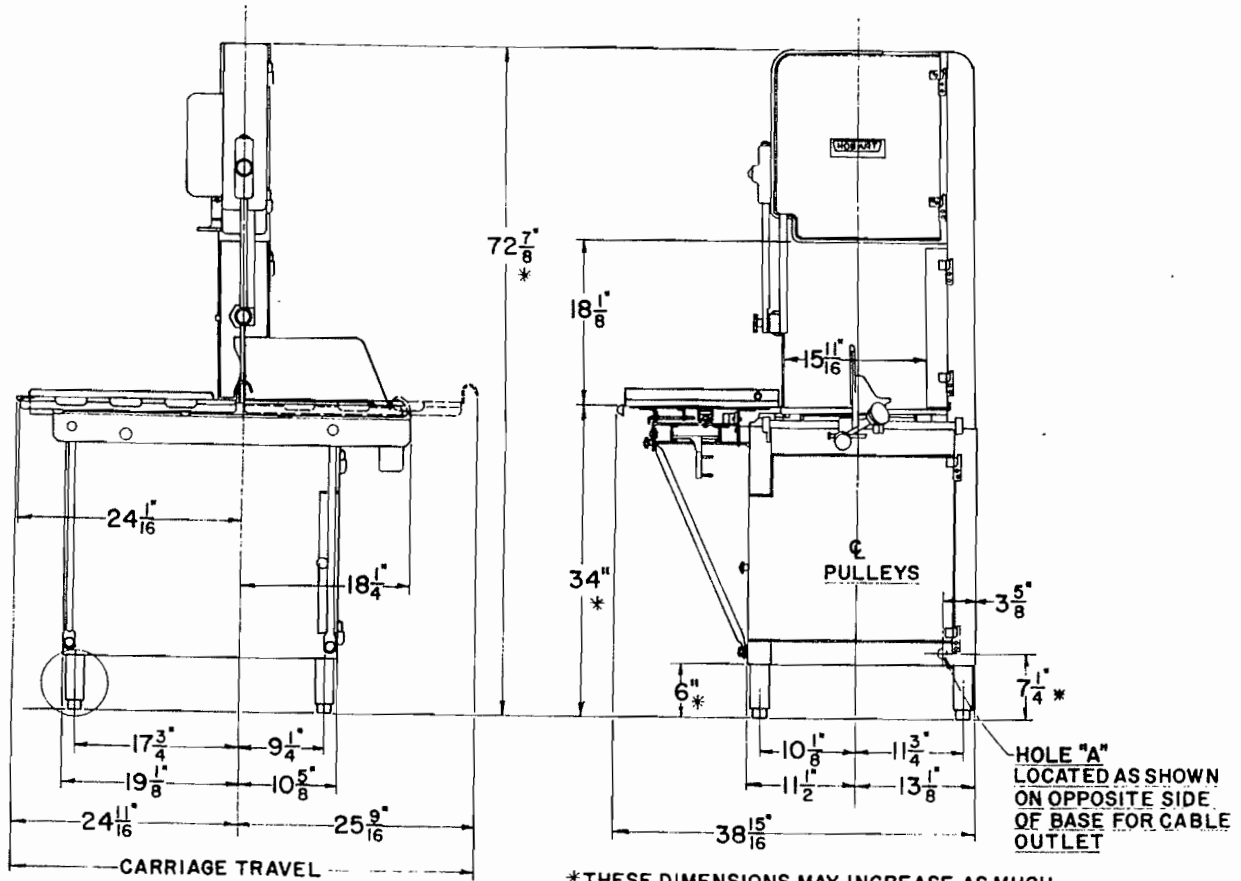

\*THESE DIMENSIONS MAY INCREASE AS MUCH  
AS 1/2" DEPENDING ON LEG ADJUSTMENT

HOLE "A"	USE
7/8" DIA.	ALL VOLTAGES (EXCEPT 115 V.)
1-1/16" DIA.	115 V.

PL-5167

R-79778

INSTALLATION DIAGRAM